

CY8C24094, CY8C24794, CY8C24894, and CY8C24994

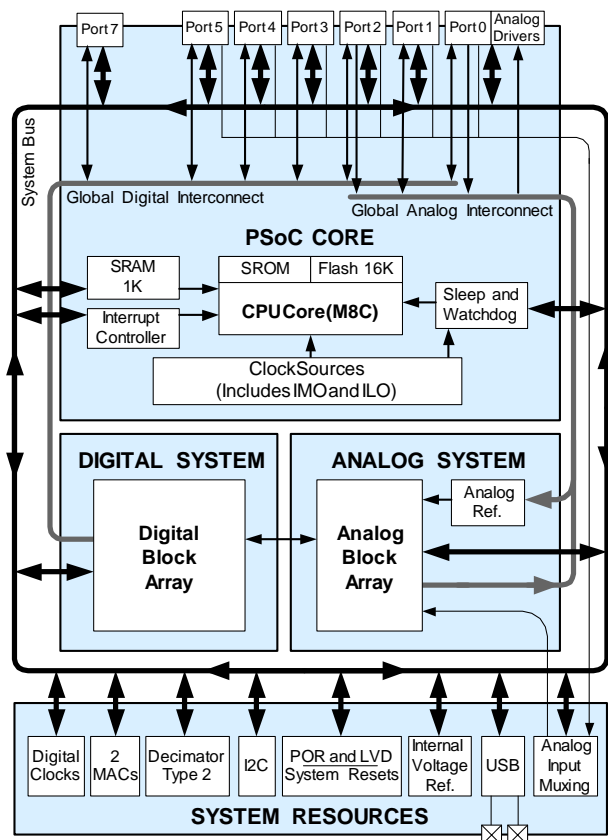

Features

- CY8C24894 includes an XRES pin to support In-System Serial Programming (ISSP) and external reset control**
- Powerful Harvard Architecture Processor**
 - M8C Processor Speeds to 24 MHz
 - Two 8x8 Multiply, 32-Bit Accumulate
 - Low Power at High Speed
 - 3.0 to 5.25V Operating Voltage
 - Industrial Temperature Range: -40°C to +85°C
 - USB Temperature Range: -10°C to +85°C
- Advanced Peripherals (PSoC Blocks)**
 - 6 Rail-to-Rail Analog PSoC Blocks Provide:
 - Up to 14-Bit ADCs
 - Up to 9-Bit DACs
 - Programmable Gain Amplifiers
 - Programmable Filters and Comparators
 - 4 Digital PSoC Blocks Provide:
 - 8- to 32-Bit Timers, Counters, and PWMs
 - CRC and PRS Modules
 - Full-Duplex UART
 - Multiple SPI™ Masters or Slaves
 - Connectable to all GPIO Pins
 - Complex Peripherals by Combining Blocks
 - Capacitive Sensing Application Capability
- Full-Speed USB (12 Mbps)**
 - Four Uni-Directional Endpoints
 - One Bi-Directional Control Endpoint
 - USB 2.0 Compliant
 - Dedicated 256 Byte Buffer
 - No External Crystal Required
- Precision, Programmable Clocking**
 - Internal ±4% 24/48 MHz Oscillator
 - Internal Oscillator for Watchdog and Sleep
 - .25% Accuracy for USB with no External Components
- Additional System Resources**
 - I²C™ Slave, Master, and Multi-Master to 400 kHz
 - Watchdog and Sleep Timers
 - User-Configurable Low Voltage Detection
 - Integrated Supervisory Circuit
 - On-Chip Precision Voltage Reference
- Complete Development Tools**
 - Free Development Software (PSoC Designer™)
 - Full-Featured, In-Circuit Emulator and Programmer
 - Full Speed Emulation
 - Complex Breakpoint Structure
 - 128K Bytes Trace Memory
- Flexible On-Chip Memory**
 - 16K Flash Program Storage 50,000 Erase/Write Cycles
 - 1K SRAM Data Storage
 - In-System Programming (ISSP)
 - Partial Flash Updates
 - Flexible Protection Modes
 - EEPROM Emulation in Flash
- Programmable Pin Configurations**
 - 25 mA Sink on all GPIO
 - Pull up, Pull down, High Z, Strong, or Open Drain Drive Modes on all GPIO
 - Up to 48 Analog Inputs on GPIO
 - Two 33 mA Analog Outputs on GPIO
 - Configurable Interrupt on all GPIO



PSoC® Functional Overview

The PSoC® family consists of many *Mixed-Signal Array with On-Chip Controller* devices. All PSoC family devices are designed to replace traditional MCUs, system ICs, and the numerous discrete components that surround them. The PSoC CY8C24x94 devices are unique members of the PSoC family because it includes a full-featured, full-speed (12 Mbps) USB port. Configurable analog, digital, and interconnect circuitry enable a high level of integration in a host of industrial, consumer, and communication applications.

This architecture allows the user to create customized peripheral configurations that match the requirements of each individual application. Additionally, a fast CPU, Flash program memory, SRAM data memory, and configurable IO are included in a range of convenient pinouts and packages.

The PSoC architecture, as illustrated on the left, is comprised of four main areas: PSoC Core, Digital System, Analog System, and System Resources including a full-speed USB port. Configurable global busing allows all the device resources to be combined into a complete custom system. The PSoC CY8C24x94 devices can have up to seven IO ports that connect to the global digital and analog interconnects, providing access to 4 digital blocks and 6 analog blocks.

The PSoC Core

The PSoC Core is a powerful engine that supports a rich feature set. The core includes a CPU, memory, clocks, and configurable GPIO (General Purpose IO).

The M8C CPU core is a powerful processor with speeds up to 24 MHz, providing a four MIPS 8-bit Harvard architecture micro-processor. The CPU utilizes an interrupt controller with up to 20 vectors, to simplify programming of real time embedded events. Program execution is timed and protected using the included Sleep and Watch Dog Timers (WDT).

Memory encompasses 16K of Flash for program storage, 1K of SRAM for data storage, and up to 2K of EEPROM emulated using the Flash. Program Flash utilizes four protection levels on blocks of 64 bytes, allowing customized software IP protection.

The PSoC device incorporates flexible internal clock generators, including a 24 MHz IMO (internal main oscillator) accurate to 8% over temperature and voltage. The 24 MHz IMO can also be doubled to 48 MHz for use by the digital system. A low power 32 kHz ILO (internal low speed oscillator) is provided for the Sleep timer and WDT. The clocks, together with programmable clock dividers (as a System Resource), provide the flexibility to integrate almost any timing requirement into the PSoC device. In USB systems, the IMO will self-tune to $\pm 0.25\%$ accuracy for USB communication.

PSoC GPIOs provide connection to the CPU, digital and analog resources of the device. Each pin's drive mode may be selected from eight options, allowing great flexibility in external interfacing. Every pin also has the capability to generate a system interrupt on high level, low level, and change from last read.

The Digital System

The Digital System is composed of 4 digital PSoC blocks. Each block is an 8-bit resource that can be used alone or combined with other blocks to form 8, 16, 24, and 32-bit peripherals, which are called user module references.

Digital System Block Diagram

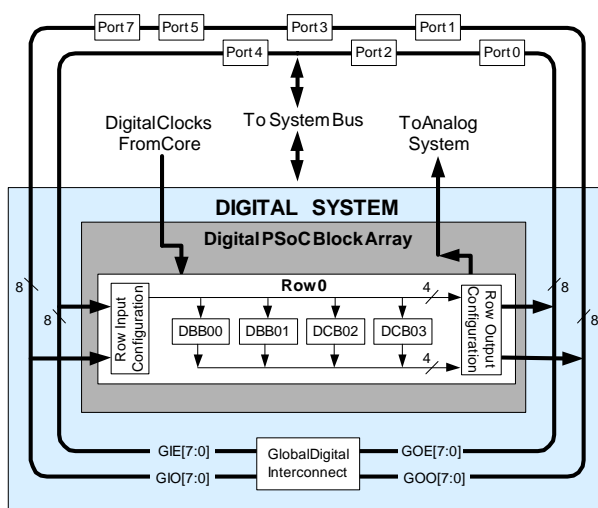

Digital peripheral configurations include those listed below.

- Full-Speed USB (12 Mbps)
- PWMs (8 to 32 bit)
- PWMs with Dead band (8 to 24 bit)
- Counters (8 to 32 bit)
- Timers (8 to 32 bit)
- UART 8 bit with selectable parity
- SPI master and slave
- I2C slave and multi-master
- Cyclical Redundancy Checker/Generator (8 to 32 bit)
- IrDA
- Pseudo Random Sequence Generators (8 to 32 bit)

The digital blocks can be connected to any GPIO through a series of global buses that can route any signal to any pin. The buses also allow for signal multiplexing and for performing logic operations. This configurability frees your designs from the constraints of a fixed peripheral controller.

Digital blocks are provided in rows of four, where the number of blocks varies by PSoC device family. This allows you the optimum choice of system resources for your application. Family resources are shown in the table titled PSoC Device Characteristics.

The Analog System

The Analog System is composed of 6 configurable blocks, each comprised of an opamp circuit allowing the creation of complex analog signal flows. Analog peripherals are very flexible and can be customized to support specific application requirements. Some of the more common PSoC analog functions (most available as user modules) are listed below.

- Analog-to-digital converters (up to 2, with 6- to 14-bit resolution, selectable as Incremental, Delta Sigma, and SAR)
- Filters (2 and 4 pole band-pass, low-pass, and notch)
- Amplifiers (up to 2, with selectable gain to 48x)
- Instrumentation amplifiers (1 with selectable gain to 93x)
- Comparators (up to 2, with 16 selectable thresholds)
- DACs (up to 2, with 6- to 9-bit resolution)
- Multiplying DACs (up to 2, with 6- to 9-bit resolution)
- High current output drivers (two with 30 mA drive as a PSoC Core Resource)
- 1.3V reference (as a System Resource)
- DTMF Dialer
- Modulators
- Correlators
- Peak Detectors
- Many other topologies possible

Analog blocks are arranged in a column of three, which includes one CT (Continuous Time) and two SC (Switched Capacitor) blocks, as shown in the figure below.

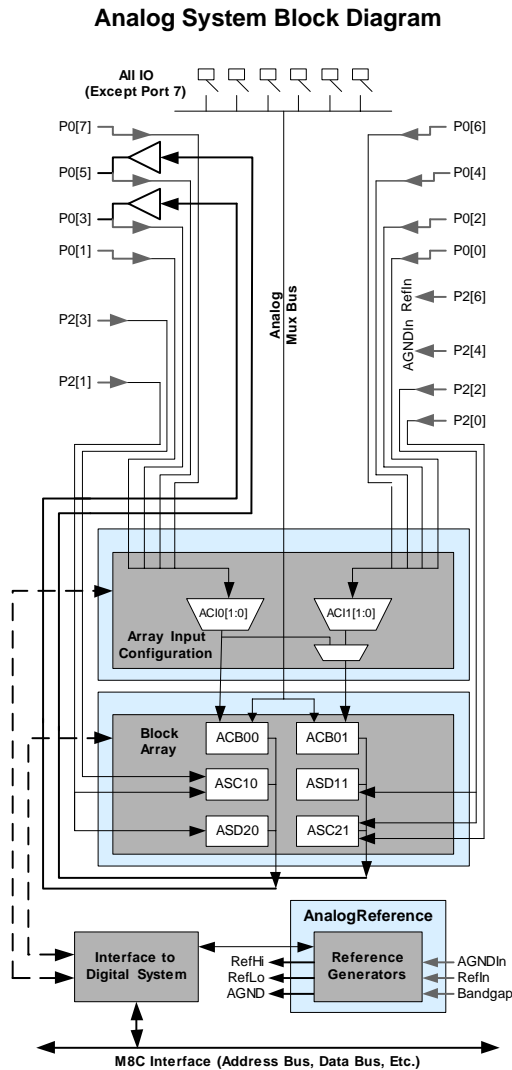

The Analog Multiplexer System

The Analog Mux Bus can connect to every GPIO pin in ports 0-5. Pins can be connected to the bus individually or in any combination. The bus also connects to the analog system for analysis with comparators and analog-to-digital converters. It can be split into two sections for simultaneous dual-channel processing. An additional 8:1 analog input multiplexer provides a second path to bring Port 0 pins to the analog array.

Switch control logic enables selected pins to precharge continuously under hardware control. This enables capacitive measurement for applications such as touch sensing. Other multiplexer applications include:

- Track pad, finger sensing.
- Chip-wide mux that allows analog input from up to 48 IO pins.
- Crosspoint connection between any IO pin combinations.

When designing capacitive sensing applications, refer to the latest signal-to-noise signal level requirements Application Notes, which can be found under <http://www.cypress.com> >> DESIGN RESOURCES >> Application Notes. In general, and unless otherwise noted in the relevant Application Notes, the minimum signal-to-noise ratio (SNR) for CapSense applications is 5:1.

Additional System Resources

System Resources, provide additional capability useful to complete systems. Additional resources include a multiplier, decimator, low voltage detection, and power on reset. Brief statements describing the merits of each resource follow.

- Full-Speed USB (12 Mbps) with 5 configurable endpoints and 256 bytes of RAM. No external components required except two series resistors. Wider than commercial temperature USB operation (-10°C to +85°C).
- Digital clock dividers provide three customizable clock frequencies for use in applications. The clocks can be routed to both the digital and analog systems. Additional clocks can be generated using digital PSoC blocks as clock dividers.
- Two multiply accumulates (MACs) provide fast 8-bit multipliers with 32-bit accumulate, to assist in both general math as well as digital filters.
- Decimator provides a custom hardware filter for digital signal processing apps. including creation of Delta Sigma ADCs.
- The I2C module provides 100 and 400 kHz communication over two wires. Slave, master, multi-master are supported.
- Low Voltage Detection (LVD) interrupts signal the application of falling voltage levels, while the advanced POR (Power On Reset) circuit eliminates the need for a system supervisor.
- An internal 1.3V reference provides an absolute reference for the analog system, including ADCs and DACs.
- Versatile analog multiplexer system.

PSoC Device Characteristics

Depending on your PSoC device characteristics, the digital and analog systems can have 16, 8, or 4 digital blocks and 12, 6, or 4 analog blocks. The following table lists the resources available for specific PSoC device groups. The device covered by this data sheet is shown in the highlighted row of the table

PSoC Device Characteristics

PSoC Part Number	Digital IO	Digital Rows	Digital Blocks	Analog Inputs	Analog Outputs	Analog Columns	Analog Blocks	SRAM Size	Flash Size
CY8C29x66	up to 64	4	16	12	4	4	12	2K	32K
CY8C27x43	up to 44	2	8	12	4	4	12	256 Bytes	16K
CY8C24x94	56	1	4	48	2	2	6	1K	16K
CY8C24x23A	up to 24	1	4	12	2	2	6	256 Bytes	4K
CY8C21x34	up to 28	1	4	28	0	2	4 ^a	512 Bytes	8K
CY8C21x23	16	1	4	8	0	2	4 ^a	256 Bytes	4K
CY8C20x34	up to 28	0	0	28	0	0	3 ^b	512 Bytes	8K

a. Limited analog functionality.

b. Two analog blocks and one CapSense.

Getting Started

The quickest path to understanding the PSoC silicon is by reading this data sheet and using the PSoC Designer Integrated Development Environment (IDE). This data sheet is an overview of the PSoC integrated circuit and presents specific pin, register, and electrical specifications. For in-depth information, along with detailed programming information, reference the *PSoC Mixed-Signal Array Technical Reference Manual*.

For up-to-date Ordering, Packaging, and Electrical Specification information, reference the latest PSoC device data sheets on the web at <http://www.cypress.com/psoc>.

To determine which PSoC device meets your requirements, navigate through the PSoC Decision Tree in the Application Note AN2209 at <http://www.cypress.com> and select Application Notes under the Design Resources.

Development Kits

Development Kits are available from the following distributors: Digi-Key, Avnet, Arrow, and Future. The Cypress Online Store contains development kits, C compilers, and all accessories for PSoC development. Go to the Cypress Online Store web site at <http://www.cypress.com>, click the Online Store shopping cart icon at the bottom of the web page, and click *PSoC (Programmable System-on-Chip)* to view a current list of available items.

Technical Training Modules

Free PSoC technical training modules are available for users new to PSoC. Training modules cover designing, debugging, advanced analog and CapSense. Go to <http://www.cypress.com/techtrain>.

Consultants

Certified PSoC Consultants offer everything from technical assistance to completed PSoC designs. To contact or become a PSoC Consultant go to <http://www.cypress.com>, click on Design Support located on the left side of the web page, and select CYPros Consultants.

Technical Support

PSoC application engineers take pride in fast and accurate response. They can be reached with a 4-hour guaranteed response at <http://www.cypress.com/support/login.cfm>.

Application Notes

A long list of application notes will assist you in every aspect of your design effort. To view the PSoC application notes, go to the <http://www.cypress.com> web site and select Application Notes under the Design Resources list located in the center of the web page. Application notes are listed by date as default.

Development Tools

PSoC Designer is a Microsoft® Windows-based, integrated development environment for the Programmable System-on-Chip (PSoC) devices. The PSoC Designer IDE and application runs on Windows NT 4.0, Windows 2000, Windows Millennium (Me), or Windows XP. (Reference the PSoC Designer Functional Flow diagram below.)

PSoC Designer helps the customer to select an operating configuration for the PSoC, write application code that uses the PSoC, and debug the application. This system provides design database management by project, an integrated debugger with In-Circuit Emulator, in-system programming support, and the CYASM macro assembler for the CPUs.

PSoC Designer also supports a high-level C language compiler developed specifically for the devices in the family.

PSoC Designer Subsystems

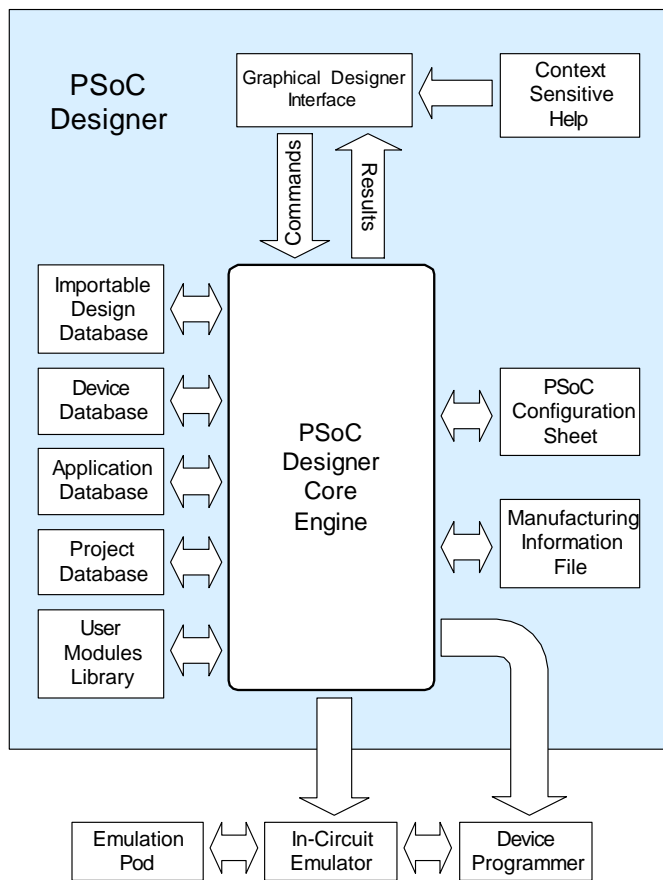

PSoC Designer Software Subsystems

Device Editor

The Device Editor subsystem allows the user to select different onboard analog and digital components called user modules using the PSoC blocks. Examples of user modules are ADCs, DACs, Amplifiers, and Filters.

The device editor also supports easy development of multiple configurations and dynamic reconfiguration. Dynamic configuration allows for changing configurations at run time.

PSoC Designer sets up power-on initialization tables for selected PSoC block configurations and creates source code for an application framework. The framework contains software to operate the selected components and, if the project uses more than one operating configuration, contains routines to switch between different sets of PSoC block configurations at run time. PSoC Designer can print out a configuration sheet for a given project configuration for use during application programming in conjunction with the Device Data Sheet. Once the framework is generated, the user can add application-specific code to flesh out the framework. It's also possible to change the selected components and regenerate the framework.

Design Browser

The Design Browser allows users to select and import preconfigured designs into the user's project. Users can easily browse a catalog of preconfigured designs to facilitate time-to-design. Examples provided in the tools include a 300-baud modem, LIN Bus master and slave, fan controller, and magnetic card reader.

Application Editor

In the Application Editor you can edit your C language and Assembly language source code. You can also assemble, compile, link, and build.

Assembler. The macro assembler allows the assembly code to be merged seamlessly with C code. The link libraries automatically use absolute addressing or can be compiled in relative mode, and linked with other software modules to get absolute addressing.

C Language Compiler. A C language compiler is available that supports the PSoC family of devices. Even if you have never worked in the C language before, the product quickly allows you to create complete C programs for the PSoC family devices.

The embedded, optimizing C compiler provides all the features of C tailored to the PSoC architecture. It comes complete with embedded libraries providing port and bus operations, standard keypad and display support, and extended math functionality.

Debugger

The PSoC Designer Debugger subsystem provides hardware in-circuit emulation, allowing the designer to test the program in a physical system while providing an internal view of the PSoC device. Debugger commands allow the designer to read and program and read and write data memory, read and write IO registers, read and write CPU registers, set and clear breakpoints, and provide program run, halt, and step control. The debugger also allows the designer to create a trace buffer of registers and memory locations of interest.

Online Help System

The online help system displays online, context-sensitive help for the user. Designed for procedural and quick reference, each functional subsystem has its own context-sensitive help. This system also provides tutorials and links to FAQs and an Online Support Forum to aid the designer in getting started.

Hardware Tools

In-Circuit Emulator

A low cost, high functionality ICE (In-Circuit Emulator) is available for development support. This hardware has the capability to program single devices.

The emulator consists of a base unit that connects to the PC by way of a USB port. The base unit is universal and will operate with all PSoC devices. Emulation pods for each device family are available separately. The emulation pod takes the place of the PSoC device in the target board and performs full speed (24 MHz) operation.

Designing with User Modules

The development process for the PSoC device differs from that of a traditional fixed function microprocessor. The configurable analog and digital hardware blocks give the PSoC architecture a unique flexibility that pays dividends in managing specification change during development and by lowering inventory costs. These configurable resources, called PSoC Blocks, have the ability to implement a wide variety of user-selectable functions. Each block has several registers that determine its function and connectivity to other blocks, multiplexers, buses and to the IO pins. Iterative development cycles permit you to adapt the hardware as well as the software. This substantially lowers the risk of having to select a different part to meet the final design requirements.

To speed the development process, the PSoC Designer Integrated Development Environment (IDE) provides a library of pre-built, pre-tested hardware peripheral functions, called “User Modules.” User modules make selecting and implementing peripheral devices simple, and come in analog, digital, and mixed signal varieties. The standard User Module library contains over 50 common peripherals such as ADCs, DACs Timers, Counters, UARTs, and other not-so common peripherals such as DTMF Generators and Bi-Quad analog filter sections.

Each user module establishes the basic register settings that implement the selected function. It also provides parameters that allow you to tailor its precise configuration to your particular application. For example, a Pulse Width Modulator User Module configures one or more digital PSoC blocks, one for each 8 bits of resolution. The user module parameters permit you to establish the pulse width and duty cycle. User modules also provide tested software to cut your development time. The user module application programming interface (API) provides high-level functions to control and respond to hardware events at run-time. The API also provides optional interrupt service routines that you can adapt as needed.

The API functions are documented in user module data sheets that are viewed directly in the PSoC Designer IDE. These data sheets explain the internal operation of the user module and provide performance specifications. Each data sheet describes the use of each user module parameter and documents the setting of each register controlled by the user module.

The development process starts when you open a new project and bring up the Device Editor, a graphical user interface (GUI) for configuring the hardware. You pick the user modules you need for your project and map them onto the PSoC blocks with point-and-click simplicity. Next, you build signal chains by interconnecting user modules to each other and the IO pins. At this stage, you also configure the clock source connections and enter parameter values directly or by selecting values from drop-down menus. When you are ready to test the hardware configuration or move on to developing code for the project, you perform the “Generate Application” step. This causes PSoC Designer to generate source code that automatically configures the device to your specification and provides the high-level user module API functions.

User Module/Source Code Development Flows

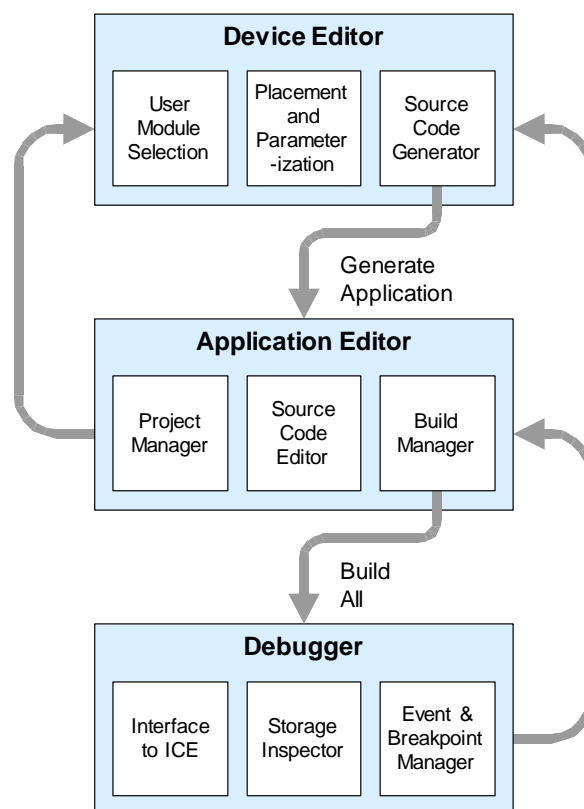

The next step is to write your main program, and any sub-routines using PSoC Designer’s Application Editor subsystem. The Application Editor includes a Project Manager that allows you to open the project source code files (including all generated code files) from a hierarchical view. The source code editor provides syntax coloring and advanced edit features for both C and assembly language. File search capabilities include simple string searches and recursive “grep-style” patterns. A single mouse click invokes the Build Manager. It employs a professional-strength “makefile” system to automatically analyze all file dependencies and run the compiler and assembler as necessary. Project-level options control optimization strategies used by the compiler and linker. Syntax errors are displayed in a console window. Double clicking the error message takes you directly to the offending line of source code. When all is correct, the linker builds a HEX file image suitable for programming.

The last step in the development process takes place inside the PSoC Designer’s Debugger subsystem. The Debugger downloads the HEX image to the In-Circuit Emulator (ICE) where it runs at full speed. Debugger capabilities rival those of systems costing many times more. In addition to traditional single-step, run-to-breakpoint and watch-variable features, the Debugger provides a large trace buffer and allows you define complex breakpoint events that include monitoring address and data bus values, memory locations and external signals.

Document Conventions

Acronyms Used

The following table lists the acronyms that are used in this document.

Acronym	Description
AC	alternating current
ADC	analog-to-digital converter
API	application programming interface
CPU	central processing unit
CT	continuous time
DAC	digital-to-analog converter
DC	direct current
ECO	external crystal oscillator
EEPROM	electrically erasable programmable read-only memory
FSR	full scale range
GPIO	general purpose IO
GUI	graphical user interface
HBM	human body model
ICE	in-circuit emulator
ILO	internal low speed oscillator
IMO	internal main oscillator
IO	input/output
IPOR	imprecise power on reset
LSb	least-significant bit
LVD	low voltage detect
MSb	most-significant bit
PC	program counter
PLL	phase-locked loop
POR	power on reset
PPOR	precision power on reset
PSoC®	Programmable System-on-Chip™
PWM	pulse width modulator
SC	switched capacitor
SRAM	static random access memory

Units of Measure

A units of measure table is located in the Electrical Specifications section. [Table 3-1 on page 22](#) lists all the abbreviations used to measure the PSoC devices.

Numeric Naming

Hexidecimal numbers are represented with all letters in upper-case with an appended lowercase 'h' (for example, '14h' or '3Ah'). Hexidecimal numbers may also be represented by a '0x' prefix, the C coding convention. Binary numbers have an appended lowercase 'b' (e.g., '01010100b' or '01000011b'). Numbers not indicated by an 'h' or 'b' are decimal.

Table of Contents

For an in depth discussion and more information on your PSoC device, obtain the *PSoC Mixed-Signal Array Technical Reference Manual*. This document encompasses and is organized into the following chapters and sections.

1. Pin Information	9
1.1 56-Pin Part Pinout	9
1.2 56-Pin Part Pinout (with XRES)	10
1.3 68-Pin Part Pinout	11
1.4 68-Pin Part Pinout (On-Chip Debug)	12
1.5 100-Ball VFBGA Part Pinout	13
1.6 100-Ball VFBGA Part Pinout (On-Chip Debug)	15
1.7 100-Pin Part Pinout (On-Chip Debug)	17
2. Register Reference	19
2.1 Register Conventions	19
2.1.1 Abbreviations Used	19
2.2 Register Mapping Tables	19
3. Electrical Specifications	22
3.1 Absolute Maximum Ratings	23
3.2 Operating Temperature	23
3.3 DC Electrical Characteristics	23
3.3.1 DC Chip-Level Specifications	23
3.3.2 DC General Purpose IO Specifications	24
3.3.3 DC Full-Speed USB Specifications	24
3.3.4 DC Operational Amplifier Specifications	25
3.3.5 DC Low Power Comparator Specifications	26
3.3.6 DC Analog Output Buffer Specifications	27
3.3.7 DC Analog Reference Specifications	28
3.3.8 DC Analog PSoC Block Specifications	29
3.3.9 DC POR and LVD Specifications	29
3.3.10 DC Programming Specifications	30
3.4 AC Electrical Characteristics	31
3.4.1 AC Chip-Level Specifications	31
3.4.2 AC General Purpose IO Specifications	32
3.4.3 AC Full-Speed USB Specifications	32
3.4.4 AC Operational Amplifier Specifications	33
3.4.5 AC Low Power Comparator Specifications	35
3.4.6 AC Digital Block Specifications	35
3.4.7 AC External Clock Specifications	35
3.4.8 AC Analog Output Buffer Specifications	36
3.4.9 AC Programming Specifications	37
3.4.10 AC I2C Specifications	38
4. Packaging Information	39
4.1 Packaging Dimensions	39
4.2 Thermal Impedance	42
4.3 Solder Reflow Peak Temperature	42
5. Development Tool Selection	43
5.1 Software	43
5.1.1 PSoC Designer	43
5.1.2 PSoC Express	43
5.1.3 PSoC Programmer	43
5.1.4 CY3202-C iMAGEcraft C Compiler	43
5.2 Development Kits	43
5.2.1 CY3215-DK Basic Development Kit	43
5.2.2 CY3210-ExpressDK Development Kit	44
5.3 Evaluation Tools	44
5.3.1 CY3210-MiniProg1	44
5.3.2 CY3210-PSoCEval1	44
5.3.3 CY3214-PSoCEvalUSB	44
5.4 Device Programmers	44
5.4.1 CY3216 Modular Programmer	44
5.4.2 CY3207ISSP In-System Serial Programmer (ISSP)	44
5.5 Accessories (Emulation and Programming)	45
5.6 3rd-Party Tools	45
5.7 Build a PSoC Emulator into Your Board	45
6. Ordering Information	46
6.1 Ordering Code Definitions	46
7. Sales and Company Information	47
7.1 Revision History	47
7.2 Copyrights and Code Protection	48

1. Pin Information



This chapter describes, lists, and illustrates the CY8C24x94 PSoC device family pins and pinout configuration.

The CY8C24x94 PSoC devices are available in the following packages, all of which are shown on the following pages. Every port pin (labeled with a "P") is capable of Digital IO. However, Vss, Vdd, and XRES are not capable of Digital IO.

1.1 56-Pin Part Pinout

Table 1-1. 56-Pin Part Pinout (QFN)** See LEGEND details and footnotes in [Table 1-2 on page 10](#).

Pin No.	Type		Name	Description
	Digital	Analog		
1	IO	I, M	P2[3]	Direct switched capacitor block input.
2	IO	I, M	P2[1]	Direct switched capacitor block input.
3	IO	M	P4[7]	
4	IO	M	P4[5]	
5	IO	M	P4[3]	
6	IO	M	P4[1]	
7	IO	M	P3[7]	
8	IO	M	P3[5]	
9	IO	M	P3[3]	
10	IO	M	P3[1]	
11	IO	M	P5[7]	
12	IO	M	P5[5]	
13	IO	M	P5[3]	
14	IO	M	P5[1]	
15	IO	M	P1[7]	I2C Serial Clock (SCL).
16	IO	M	P1[5]	I2C Serial Data (SDA).
17	IO	M	P1[3]	
18	IO	M	P1[1]	I2C Serial Clock (SCL), ISSP SCLK*.
19	Power		Vss	Ground connection.
20	USB		D+	
21	USB		D-	
22	Power		Vdd	Supply voltage.
23	IO		P7[7]	
24	IO		P7[0]	
25	IO	M	P1[0]	I2C Serial Data (SDA), ISSP SDATA*.
26	IO	M	P1[2]	
27	IO	M	P1[4]	
28	IO	M	P1[6]	
29	IO	M	P5[0]	
30	IO	M	P5[2]	
31	IO	M	P5[4]	
32	IO	M	P5[6]	
33	IO	M	P3[0]	
34	IO	M	P3[2]	
35	IO	M	P3[4]	
36	IO	M	P3[6]	
37	IO	M	P4[0]	
38	IO	M	P4[2]	
39	IO	M	P4[4]	
40	IO	M	P4[6]	
41	IO	I, M	P2[0]	Direct switched capacitor block input.
42	IO	I, M	P2[2]	Direct switched capacitor block input.
43	IO	M	P2[4]	External Analog Ground (AGND) input.
44	IO	M	P2[6]	External Voltage Reference (VREF) input.
45	IO	I, M	P0[0]	Analog column mux input.
46	IO	I, M	P0[2]	Analog column mux input.
47	IO	I, M	P0[4]	Analog column mux input VREF.
48	IO	I, M	P0[6]	Analog column mux input.
49	Power		Vdd	Supply voltage.
50	Power		Vss	Ground connection.
51	IO	I, M	P0[7]	Analog column mux input,.
52	IO	IO, M	P0[5]	Analog column mux input and column output.
53	IO	IO, M	P0[3]	Analog column mux input and column output.
54	IO	I, M	P0[1]	Analog column mux input.
55	IO	M	P2[7]	
56	IO	M	P2[5]	

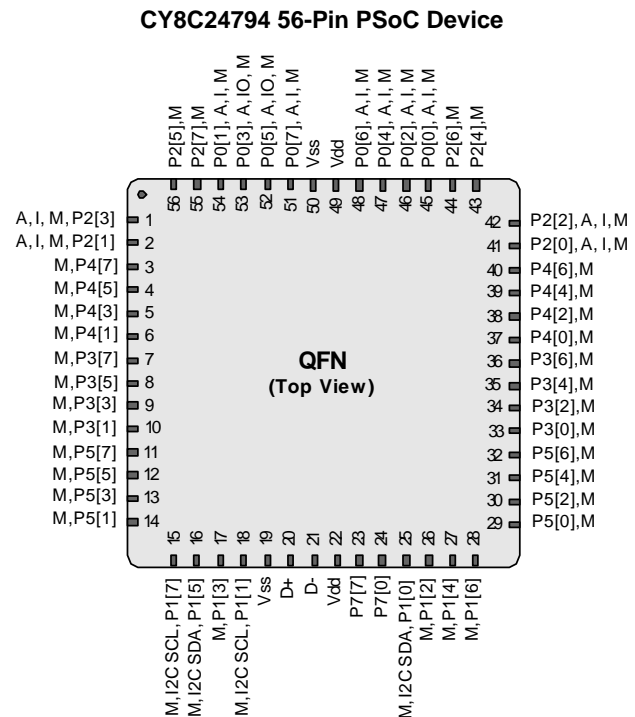

Pin No.	Type		Name	Description
	Digital	Analog		
44	IO	M	P2[6]	External Voltage Reference (VREF) input.
45	IO	I, M	P0[0]	Analog column mux input.
46	IO	I, M	P0[2]	Analog column mux input.
47	IO	I, M	P0[4]	Analog column mux input VREF.
48	IO	I, M	P0[6]	Analog column mux input.
49	Power		Vdd	Supply voltage.
50	Power		Vss	Ground connection.
51	IO	I, M	P0[7]	Analog column mux input,.
52	IO	IO, M	P0[5]	Analog column mux input and column output.
53	IO	IO, M	P0[3]	Analog column mux input and column output.
54	IO	I, M	P0[1]	Analog column mux input.
55	IO	M	P2[7]	
56	IO	M	P2[5]	

1.2 56-Pin Part Pinout (with XRES)

Table 1-2. 56-Pin Part Pinout (QFN**)

Pin No.	Type		Name	Description
	Digital	Analog		
1	IO	I, M	P2[3]	Direct switched capacitor block input.
2	IO	I, M	P2[1]	Direct switched capacitor block input.
3	IO	M	P4[7]	
4	IO	M	P4[5]	
5	IO	M	P4[3]	
6	IO	M	P4[1]	
7	IO	M	P3[7]	
8	IO	M	P3[5]	
9	IO	M	P3[3]	
10	IO	M	P3[1]	
11	IO	M	P5[7]	
12	IO	M	P5[5]	
13	IO	M	P5[3]	
14	IO	M	P5[1]	
15	IO	M	P1[7]	I2C Serial Clock (SCL).
16	IO	M	P1[5]	I2C Serial Data (SDA).
17	IO	M	P1[3]	
18	IO	M	P1[1]	I2C Serial Clock (SCL), ISSP SCLC*.
19	Power		Vss	Ground connection.
20	USB		D+	
21	USB		D-	
22	Power		Vdd	Supply voltage.
23	IO		P7[7]	
24	IO		P7[0]	
25	IO	M	P1[0]	I2C Serial Data (SDA), ISSP SDA*.
26	IO	M	P1[2]	
27	IO	M	P1[4]	
28	IO	M	P1[6]	
29	IO	M	P5[0]	
30	IO	M	P5[2]	
31	IO	M	P5[4]	
32	IO	M	P5[6]	
33	IO	M	P3[0]	
34	IO	M	P3[2]	
35	IO	M	P3[4]	
36	Input		XRES	Active high external reset with internal pull down.
37	IO	M	P4[0]	
38	IO	M	P4[2]	
39	IO	M	P4[4]	
40	IO	M	P4[6]	
41	IO	I, M	P2[0]	Direct switched capacitor block input.
42	IO	I, M	P2[2]	Direct switched capacitor block input.
43	IO	M	P2[4]	External Analog Ground (AGND) input.

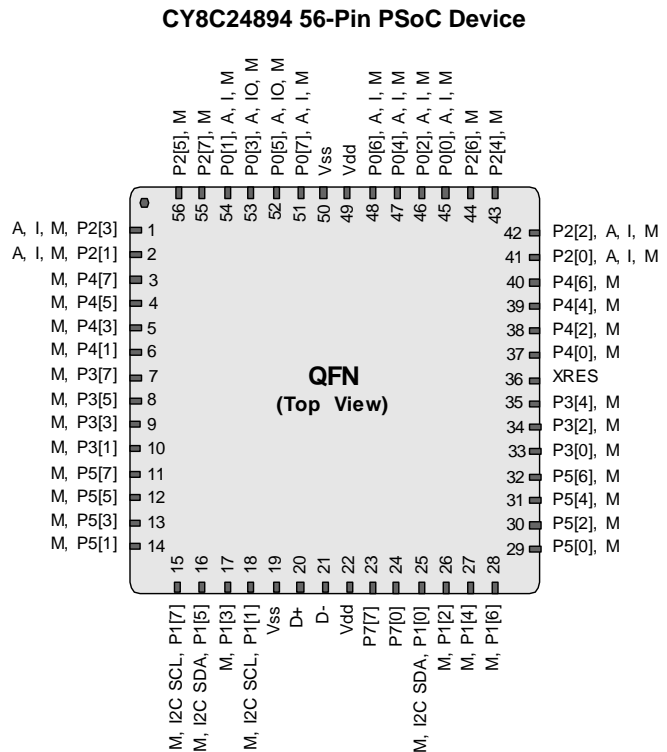

Pin No.	Type		Name	Description
	Digital	Analog		
44	IO	M	P2[6]	External Voltage Reference (VREF) input.
45	IO	I, M	P0[0]	Analog column mux input.
46	IO	I, M	P0[2]	Analog column mux input.
47	IO	I, M	P0[4]	Analog column mux input VREF.
48	IO	I, M	P0[6]	Analog column mux input.
49	Power		Vdd	Supply voltage.
50	Power		Vss	Ground connection.
51	IO	I, M	P0[7]	Analog column mux input.
52	IO	IO, M	P0[5]	Analog column mux input and column output.
53	IO	IO, M	P0[3]	Analog column mux input and column output.
54	IO	I, M	P0[1]	Analog column mux input.
55	IO	M	P2[7]	
56	IO	M	P2[5]	

LEGEND A = Analog, I = Input, O = Output, and M = Analog Mux Input.

* These are the ISSP pins, which are not High Z at POR. See the *PSoC Mixed-Signal Array Technical Reference Manual* for details.

** The center pad on the QFN package should be connected to ground (Vss) for best mechanical, thermal, and electrical performance. If not connected to ground, it should be electrically floated and not connected to any other signal.

1.4 68-Pin Part Pinout (On-Chip Debug)

The 68-pin QFN part table and drawing below is for the CY8C24094 On-Chip Debug (OCD) PSoC device.

Note This part is only used for in-circuit debugging. It is NOT available for production.

Table 1-4. 68-Pin Part Pinout (QFN)**

Pin No.	Type		Name	Description
	Digital	Analog		
1	IO	M	P4[7]	
2	IO	M	P4[5]	
3	IO	M	P4[3]	
4	IO	M	P4[1]	
5			OCDE	OCD even data IO.
6			OCDO	OCD odd data output.
7		Power	Vss	Ground connection.
8	IO	M	P3[7]	
9	IO	M	P3[5]	
10	IO	M	P3[3]	
11	IO	M	P3[1]	
12	IO	M	P5[7]	
13	IO	M	P5[5]	
14	IO	M	P5[3]	
15	IO	M	P5[1]	
16	IO	M	P1[7]	I2C Serial Clock (SCL).
17	IO	M	P1[5]	I2C Serial Data (SDA).
18	IO	M	P1[3]	
19	IO	M	P1[1]	I2C Serial Clock (SCL), ISSP SCLK*.
20		Power	Vss	Ground connection.
21		USB	D+	
22		USB	D-	
23		Power	Vdd	Supply voltage.
24	IO		P7[7]	
25	IO		P7[6]	
26	IO		P7[5]	
27	IO		P7[4]	
28	IO		P7[3]	
29	IO		P7[2]	
30	IO		P7[1]	
31	IO		P7[0]	
32	IO	M	P1[0]	I2C Serial Data (SDA), ISSP SDATA*.
33	IO	M	P1[2]	
34	IO	M	P1[4]	Optional External Clock Input (EXT-CLK).
35	IO	M	P1[6]	
36	IO	M	P5[0]	
37	IO	M	P5[2]	
38	IO	M	P5[4]	
39	IO	M	P5[6]	
40	IO	M	P3[0]	
41	IO	M	P3[2]	
42	IO	M	P3[4]	
43	IO	M	P3[6]	
44			HCLK	OCD high-speed clock output.
45			CCLK	OCD CPU clock output.
46		Input	XRES	Active high pin reset with internal pull down.
47	IO	M	P4[0]	
48	IO	M	P4[2]	
49	IO	M	P4[4]	

CY8C24094 68-Pin OCD PSoC Device

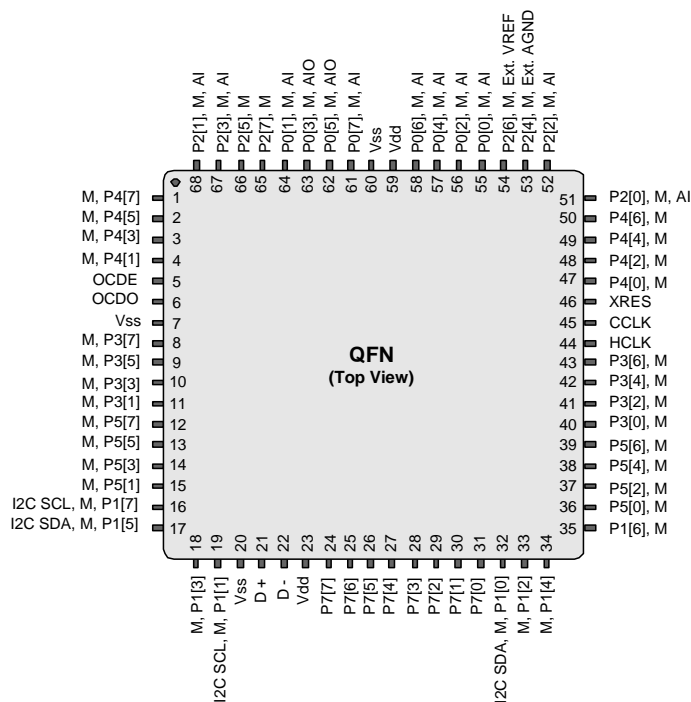

Pin No.	Type		Name	Description
	Digital	Analog		
50	IO	M	P4[6]	
51	IO	I,M	P2[0]	Direct switched capacitor block input.
52	IO	I,M	P2[2]	Direct switched capacitor block input.
53	IO	M	P2[4]	External Analog Ground (AGND) input.
54	IO	M	P2[6]	External Voltage Reference (VREF) input.
55	IO	I,M	P0[0]	Analog column mux input.
56	IO	I,M	P0[2]	Analog column mux input and column output.
57	IO	I,M	P0[4]	Analog column mux input and column output.
58	IO	I,M	P0[6]	Analog column mux input.
59		Power	Vdd	Supply voltage.
60		Power	Vss	Ground connection.
61	IO	I,M	P0[7]	Analog column mux input, integration input #1
62	IO	IO,M	P0[5]	Analog column mux input and column output, integration input #2.
63	IO	IO,M	P0[3]	Analog column mux input and column output.
64	IO	I,M	P0[1]	Analog column mux input.
65	IO	M	P2[7]	
66	IO	M	P2[5]	
67	IO	I,M	P2[3]	Direct switched capacitor block input.
68	IO	I,M	P2[1]	Direct switched capacitor block input.

LEGENDA = Analog, I = Input, O = Output, M = Analog Mux Input, OCD = On-Chip Debugger.

* These are the ISSP pins, which are not High Z at POR. See the *PSoC Mixed-Signal Array Technical Reference Manual* for details.

** The center pad on the QFN package should be connected to ground (Vss) for best mechanical, thermal, and electrical performance. If not connected to ground, it should be electrically floated and not connected to any other signal.

1.5 100-Ball VFBGA Part Pinout

The 100-ball VFBGA part is for the CY8C24994 PSoC device.

Table 1-5. 100-Ball Part Pinout (VFBGA)

Pin No.	Digital	Analog	Name	Description	Pin No.	Digital	Analog	Name	Description
A1	Power		Vss	Ground connection.	F1			NC	No connection.
A2	Power		Vss	Ground connection.	F2	IO	M	P5[7]	
A3			NC	No connection.	F3	IO	M	P3[5]	
A4			NC	No connection.	F4	IO	M	P5[1]	
A5			NC	No connection.	F5	Power		Vss	Ground connection.
A6	Power		Vdd	Supply voltage.	F6	Power		Vss	Ground connection.
A7			NC	No connection.	F7	IO	M	P5[0]	
A8			NC	No connection.	F8	IO	M	P3[0]	
A9	Power		Vss	Ground connection.	F9			XRES	Active high pin reset with internal pull down.
A10	Power		Vss	Ground connection.	F10	IO		P7[1]	
B1	Power		Vss	Ground connection.	G1			NC	No connection.
B2	Power		Vss	Ground connection.	G2	IO	M	P5[5]	
B3	IO	I,M	P2[1]	Direct switched capacitor block input.	G3	IO	M	P3[3]	
B4	IO	I,M	P0[1]	Analog column mux input.	G4	IO	M	P1[7]	I2C Serial Clock (SCL).
B5	IO	I,M	P0[7]	Analog column mux input.	G5	IO	M	P1[1]	I2C Serial Clock (SCL), ISSP SCLK*.
B6	Power		Vdd	Supply voltage.	G6	IO	M	P1[0]	I2C Serial Data (SDA), ISSP SDATA*.
B7	IO	I,M	P0[2]	Analog column mux input.	G7	IO	M	P1[6]	
B8	IO	I,M	P2[2]	Direct switched capacitor block input.	G8	IO	M	P3[4]	
B9	Power		Vss	Ground connection.	G9	IO	M	P5[6]	
B10	Power		Vss	Ground connection.	G10	IO		P7[2]	
C1			NC	No connection.	H1			NC	No connection.
C2	IO	M	P4[1]		H2	IO	M	P5[3]	
C3	IO	M	P4[7]		H3	IO	M	P3[1]	
C4	IO	M	P2[7]		H4	IO	M	P1[5]	I2C Serial Data (SDA).
C5	IO	IO,M	P0[5]	Analog column mux input and column output.	H5	IO	M	P1[3]	
C6	IO	I,M	P0[6]	Analog column mux input.	H6	IO	M	P1[2]	
C7	IO	I,M	P0[0]	Analog column mux input.	H7	IO	M	P1[4]	
C8	IO	I,M	P2[0]	Direct switched capacitor block input.	H8	IO	M	P3[2]	
C9	IO	M	P4[2]		H9	IO	M	P5[4]	
C10			NC	No connection.	H10	IO		P7[3]	
D1			NC	No connection.	J1	Power		Vss	Ground connection.
D2	IO	M	P3[7]		J2	Power		Vss	Ground connection.
D3	IO	M	P4[5]		J3	USB		D+	
D4	IO	M	P2[5]		J4	USB		D-	
D5	IO	IO,M	P0[3]	Analog column mux input and column output.	J5	Power		Vdd	Supply voltage.
D6	IO	I,M	P0[4]	Analog column mux input.	J6	IO		P7[7]	
D7	IO	M	P2[6]	External Voltage Reference (VREF) input.	J7	IO		P7[0]	
D8	IO	M	P4[6]		J8	IO	M	P5[2]	
D9	IO	M	P4[0]		J9	Power		Vss	Ground connection.
D10			NC	No connection.	J10	Power		Vss	Ground connection.
E1			NC	No connection.	K1	Power		Vss	Ground connection.
E2			NC	No connection.	K2	Power		Vss	Ground connection.
E3	IO	M	P4[3]		K3			NC	No connection.
E4	IO	I,M	P2[3]	Direct switched capacitor block input.	K4			NC	No connection.
E5	Power		Vss	Ground connection.	K5	Power		Vdd	Supply voltage.
E6	Power		Vss	Ground connection.	K6	IO		P7[6]	
E7	IO	M	P2[4]	External Analog Ground (AGND) input.	K7	IO		P7[5]	
E8	IO	M	P4[4]		K8	IO		P7[4]	
E9	IO	M	P3[6]		K9	Power		Vss	Ground connection.
E10			NC	No connection.	K10	Power		Vss	Ground connection.

LEGEND A = Analog, I = Input, O = Output, M = Analog Mux Input, NC = No Connection.

* This is the ISSP pin, which is not High Z at POR. See the *PSoC Mixed-Signal Array Technical Reference Manual* for details.

CY8C24994

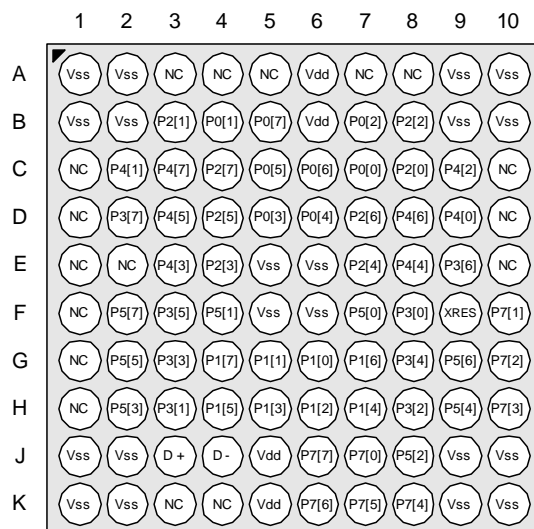

BGA (Top View)

1.6 100-Ball VFBGA Part Pinout (On-Chip Debug)

The 100-pin VFBGA part table and drawing below is for the CY8C24094 On-Chip Debug (OCD) PSoC device.

Note This part is only used for in-circuit debugging. It is NOT available for production.

Table 1-6. 100-Ball Part Pinout (VFBGA)

Pin No.	Digital	Analog	Name	Description	Pin No.	Digital	Analog	Name	Description
A1	Power		Vss	Ground connection.	F1			OCDE	OCD even data IO.
A2	Power		Vss	Ground connection.	F2	IO	M	P5[7]	
A3			NC	No connection.	F3	IO	M	P3[5]	
A4			NC	No connection.	F4	IO	M	P5[1]	
A5			NC	No connection.	F5	Power		Vss	Ground connection.
A6	Power		Vdd	Supply voltage.	F6	Power		Vss	Ground connection.
A7			NC	No connection.	F7	IO	M	P5[0]	
A8			NC	No connection.	F8	IO	M	P3[0]	
A9	Power		Vss	Ground connection.	F9			XRES	Active high pin reset with internal pull down.
A10	Power		Vss	Ground connection.	F10	IO		P7[1]	
B1	Power		Vss	Ground connection.	G1			OCDO	OCD odd data output.
B2	Power		Vss	Ground connection.	G2	IO	M	P5[5]	
B3	IO	I,M	P2[1]	Direct switched capacitor block input.	G3	IO	M	P3[3]	
B4	IO	I,M	P0[1]	Analog column mux input.	G4	IO	M	P1[7]	I2C Serial Clock (SCL).
B5	IO	I,M	P0[7]	Analog column mux input.	G5	IO	M	P1[1]	I2C Serial Clock (SCL), ISSP SCLK*.
B6	Power		Vdd	Supply voltage.	G6	IO	M	P1[0]	I2C Serial Data (SDA), ISSP SDA*.
B7	IO	I,M	P0[2]	Analog column mux input.	G7	IO	M	P1[6]	
B8	IO	I,M	P2[2]	Direct switched capacitor block input.	G8	IO	M	P3[4]	
B9	Power		Vss	Ground connection.	G9	IO	M	P5[6]	
B10	Power		Vss	Ground connection.	G10	IO		P7[2]	
C1			NC	No connection.	H1			NC	No connection.
C2	IO	M	P4[1]		H2	IO	M	P5[3]	
C3	IO	M	P4[7]		H3	IO	M	P3[1]	
C4	IO	M	P2[7]		H4	IO	M	P1[5]	I2C Serial Data (SDA).
C5	IO	IO,M	P0[5]	Analog column mux input and column output.	H5	IO	M	P1[3]	
C6	IO	I,M	P0[6]	Analog column mux input.	H6	IO	M	P1[2]	
C7	IO	I,M	P0[0]	Analog column mux input.	H7	IO	M	P1[4]	
C8	IO	I,M	P2[0]	Direct switched capacitor block input.	H8	IO	M	P3[2]	
C9	IO	M	P4[2]		H9	IO	M	P5[4]	
C10			NC	No connection.	H10	IO		P7[3]	
D1			NC	No connection.	J1	Power		Vss	Ground connection.
D2	IO	M	P3[7]		J2	Power		Vss	Ground connection.
D3	IO	M	P4[5]		J3	USB		D+	
D4	IO	M	P2[5]		J4	USB		D-	
D5	IO	IO,M	P0[3]	Analog column mux input and column output.	J5	Power		Vdd	Supply voltage.
D6	IO	I,M	P0[4]	Analog column mux input.	J6	IO		P7[7]	
D7	IO	M	P2[6]	External Voltage Reference (VREF) input.	J7	IO		P7[0]	
D8	IO	M	P4[6]		J8	IO	M	P5[2]	
D9	IO	M	P4[0]		J9	Power		Vss	Ground connection.
D10			CCLK	OCD CPU clock output.	J10	Power		Vss	Ground connection.
E1			NC	No connection.	K1	Power		Vss	Ground connection.
E2			NC	No connection.	K2	Power		Vss	Ground connection.
E3	IO	M	P4[3]		K3			NC	No connection.
E4	IO	I,M	P2[3]	Direct switched capacitor block input.	K4			NC	No connection.
E5	Power		Vss	Ground connection.	K5	Power		Vdd	Supply voltage.
E6	Power		Vss	Ground connection.	K6	IO		P7[6]	
E7	IO	M	P2[4]	External Analog Ground (AGND) input.	K7	IO		P7[5]	
E8	IO	M	P4[4]		K8	IO		P7[4]	
E9	IO	M	P3[6]		K9	Power		Vss	Ground connection.
E10			HCLK	OCD high-speed clock output.	K10	Power		Vss	Ground connection.

LEGEND A = Analog, I = Input, O = Output, M = Analog Mux Input, NC = No Connection, OCD = On-Chip Debugger.

* This is the ISSP pin, which is not High Z at POR. See the *PSoC Mixed-Signal Array Technical Reference Manual* for details.

CY8C24094 OCD

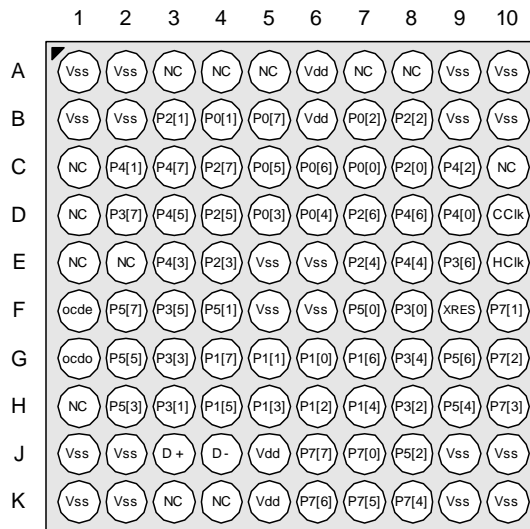

BGA (Top View)

Not for Production

1.7 100-Pin Part Pinout (On-Chip Debug)

The 100-pin TQFP part is for the CY8C24094 On-Chip Debug (OCD) PSoC device.

Note This part is only used for in-circuit debugging. It is NOT available for production.

Table 1-7. 100-Pin Part Pinout (TQFP)

Pin No.	Digital	Analog	Name	Description	Pin No.	Digital	Analog	Name	Description
1			NC	No connection.	51	IO	M	P1[6]	
2			NC	No connection.	52	IO	M	P5[0]	
3	IO	I, M	P0[1]	Analog column mux input.	53	IO	M	P5[2]	
4	IO	M	P2[7]		54	IO	M	P5[4]	
5	IO	M	P2[5]		55	IO	M	P5[6]	
6	IO	I, M	P2[3]	Direct switched capacitor block input.	56	IO	M	P3[0]	
7	IO	I, M	P2[1]	Direct switched capacitor block input.	57	IO	M	P3[2]	
8	IO	M	P4[7]		58	IO	M	P3[4]	
9	IO	M	P4[5]		59	IO	M	P3[6]	
10	IO	M	P4[3]		60			HCLK	OCD high-speed clock output.
11	IO	M	P4[1]		61			CCLK	OCD CPU clock output.
12			OCDE	OCD even data IO.	62		Input	XRES	Active high pin reset with internal pull down.
13			OCDO	OCD odd data output.	63	IO	M	P4[0]	
14			NC	No connection.	64	IO	M	P4[2]	
15	Power		Vss	Ground connection.	65	Power		Vss	Ground connection.
16	IO	M	P3[7]		66	IO	M	P4[4]	
17	IO	M	P3[5]		67	IO	M	P4[6]	
18	IO	M	P3[3]		68	IO	I, M	P2[0]	Direct switched capacitor block input.
19	IO	M	P3[1]		69	IO	I, M	P2[2]	Direct switched capacitor block input.
20	IO	M	P5[7]		70	IO		P2[4]	External Analog Ground (AGND) input.
21	IO	M	P5[5]		71			NC	No connection.
22	IO	M	P5[3]		72	IO		P2[6]	External Voltage Reference (VREF) input.
23	IO	M	P5[1]		73			NC	No connection.
24	IO	M	P1[7]	I2C Serial Clock (SCL).	74	IO	I	P0[0]	Analog column mux input.
25			NC	No connection.	75			NC	No connection.
26			NC	No connection.	76			NC	No connection.
27			NC	No connection.	77	IO	I, M	P0[2]	Analog column mux input and column output.
28	IO		P1[5]	I2C Serial Data (SDA)	78			NC	No connection.
29	IO		P1[3]		79	IO	I, M	P0[4]	Analog column mux input and column output.
30	IO		P1[1]	Crystal (XTALin), I2C Serial Clock (SCL), ISSP SCLK*.	80			NC	No connection.
31			NC	No connection.	81	IO	I, M	P0[6]	Analog column mux input.
32	Power		Vss	Ground connection.	82	Power		Vdd	Supply voltage.
33	USB		D+		83			NC	No connection.
34	USB		D-		84	Power		Vss	Ground connection.
35	Power		Vdd	Supply voltage.	85			NC	No connection.
36	IO		P7[7]		86			NC	No connection.
37	IO		P7[6]		87			NC	No connection.
38	IO		P7[5]		88			NC	No connection.
39	IO		P7[4]		89			NC	No connection.
40	IO		P7[3]		90			NC	No connection.
41	IO		P7[2]		91			NC	No connection.
42	IO		P7[1]		92			NC	No connection.
43	IO		P7[0]		93			NC	No connection.
44			NC	No connection.	94			NC	No connection.
45			NC	No connection.	95	IO	I, M	P0[7]	Analog column mux input.
46			NC	No connection.	96			NC	No connection.
47			NC	No connection.	97	IO	IO, M	P0[5]	Analog column mux input and column output.
48	IO		P1[0]	Crystal (XTALout), I2C Serial Data (SDA), ISSP SDATA*.	98			NC	No connection.
49	IO		P1[2]		99	IO	IO, M	P0[3]	Analog column mux input and column output.
50	IO		P1[4]	Optional External Clock Input (EXTCLK).	100			NC	No connection.

LEGEND A = Analog, I = Input, O = Output, NC = No Connection, M = Analog Mux Input, OCD = On-Chip Debugger.

* These are the ISSP pins, which are not High Z at POR. See the *PSoC Mixed-Signal Array Technical Reference Manual* for details.

CY8C24094 OCD

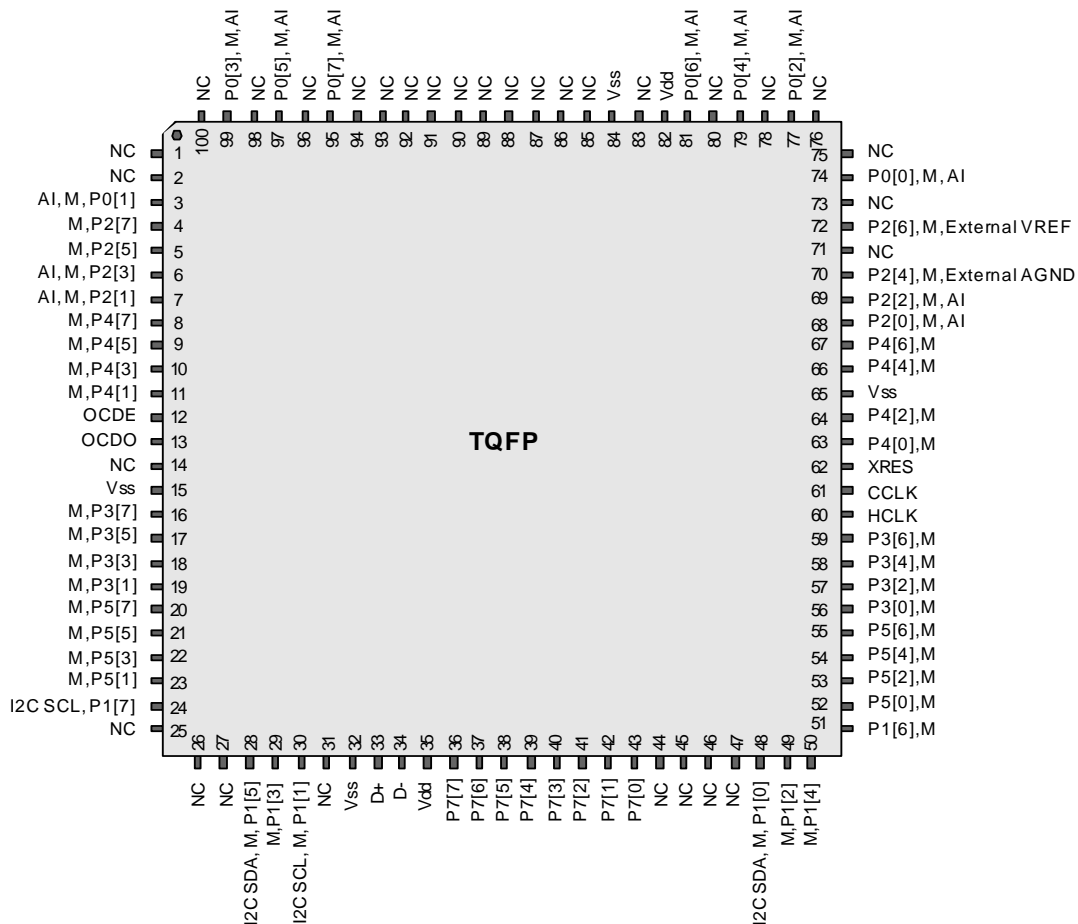

Not for Production

2. Register Reference



This chapter lists the registers of the CY8C24x94 PSoC device family. For detailed register information, reference the *PSoC Mixed-Signal Array Technical Reference Manual*.

2.1 Register Conventions

2.1.1 Abbreviations Used

The register conventions specific to this section are listed in the following table.

Convention	Description
R	Read register or bit(s)
W	Write register or bit(s)
L	Logical register or bit(s)
C	Clearable register or bit(s)
#	Access is bit specific

2.2 Register Mapping Tables

The PSoC device has a total register address space of 512 bytes. The register space is referred to as IO space and is divided into two banks. The XO1 bit in the Flag register (CPU_F) determines which bank the user is currently in. When the XO1 bit is set the user is in Bank 1.

Note In the following register mapping tables, blank fields are Reserved and should not be accessed.

Register Map Bank 0 Table: User Space

Name	Addr (0,Hex)	Access	Name	Addr (0,Hex)	Access	Name	Addr (0,Hex)	Access	Name	Addr (0,Hex)	Access
PRT0DR	00	RW	PMA0_DR	40	RW	ASC10CR0	80	RW		C0	
PRT0IE	01	RW	PMA1_DR	41	RW	ASC10CR1	81	RW		C1	
PRT0GS	02	RW	PMA2_DR	42	RW	ASC10CR2	82	RW		C2	
PRT0DM2	03	RW	PMA3_DR	43	RW	ASC10CR3	83	RW		C3	
PRT1DR	04	RW	PMA4_DR	44	RW	ASD11CR0	84	RW		C4	
PRT1IE	05	RW	PMA5_DR	45	RW	ASD11CR1	85	RW		C5	
PRT1GS	06	RW	PMA6_DR	46	RW	ASD11CR2	86	RW		C6	
PRT1DM2	07	RW	PMA7_DR	47	RW	ASD11CR3	87	RW		C7	
PRT2DR	08	RW	USB_SOF0	48	R		88			C8	
PRT2IE	09	RW	USB_SOF1	49	R		89			C9	
PRT2GS	0A	RW	USB_CR0	4A	RW		8A			CA	
PRT2DM2	0B	RW	USBIO_CR0	4B	#		8B			CB	
PRT3DR	0C	RW	USBIO_CR1	4C	RW		8C			CC	
PRT3IE	0D	RW		4D			8D			CD	
PRT3GS	0E	RW	EP1_CNT1	4E	#		8E			CE	
PRT3DM2	0F	RW	EP1_CNT	4F	RW		8F			CF	
PRT4DR	10	RW	EP2_CNT1	50	#	ASD20CR0	90	RW	CUR_PP	D0	RW
PRT4IE	11	RW	EP2_CNT	51	RW	ASD20CR1	91	RW	STK_PP	D1	RW
PRT4GS	12	RW	EP3_CNT1	52	#	ASD20CR2	92	RW		D2	
PRT4DM2	13	RW	EP3_CNT	53	RW	ASD20CR3	93	RW	IDX_PP	D3	RW
PRT5DR	14	RW	EP4_CNT1	54	#	ASC21CR0	94	RW	MVR_PP	D4	RW
PRT5IE	15	RW	EP4_CNT	55	RW	ASC21CR1	95	RW	MVW_PP	D5	RW
PRT5GS	16	RW	EP0_CR	56	#	ASC21CR2	96	RW	I2C_CFG	D6	RW
PRT5DM2	17	RW	EP0_CNT	57	#	ASC21CR3	97	RW	I2C_SCR	D7	#
	18		EP0_DR0	58	RW		98		I2C_DR	D8	RW
	19		EP0_DR1	59	RW		99		I2C_MSCR	D9	#
	1A		EP0_DR2	5A	RW		9A		INT_CLR0	DA	RW
	1B		EP0_DR3	5B	RW		9B		INT_CLR1	DB	RW
PRT7DR	1C	RW	EP0_DR4	5C	RW		9C		INT_CLR2	DC	RW
PRT7IE	1D	RW	EP0_DR5	5D	RW		9D		INT_CLR3	DD	RW
PRT7GS	1E	RW	EP0_DR6	5E	RW		9E		INT_MSK3	DE	RW
PRT7DM2	1F	RW	EP0_DR7	5F	RW		9F		INT_MSK2	DF	RW
DBB00DR0	20	#	AMX_IN	60	RW		A0		INT_MSK0	E0	RW
DBB00DR1	21	W	AMUXCFG	61	RW		A1		INT_MSK1	E1	RW
DBB00DR2	22	RW		62			A2		INT_VC	E2	RC
DBB00CR0	23	#	ARF_CR	63	RW		A3		RES_WDT	E3	W
DBB01DR0	24	#	CMP_CR0	64	#		A4		DEC_DH	E4	RC
DBB01DR1	25	W	ASY_CR	65	#		A5		DEC_DL	E5	RC
DBB01DR2	26	RW	CMP_CR1	66	RW		A6		DEC_CR0	E6	RW
DBB01CR0	27	#		67			A7		DEC_CR1	E7	RW
DCB02DR0	28	#		68		MUL1_X	A8	W	MUL0_X	E8	W
DCB02DR1	29	W		69		MUL1_Y	A9	W	MUL0_Y	E9	W
DCB02DR2	2A	RW		6A		MUL1_DH	AA	R	MUL0_DH	EA	R
DCB02CR0	2B	#		6B		MUL1_DL	AB	R	MUL0_DL	EB	R
DCB03DR0	2C	#	TMP_DR0	6C	RW	ACC1_DR1	AC	RW	ACC0_DR1	EC	RW
DCB03DR1	2D	W	TMP_DR1	6D	RW	ACC1_DR0	AD	RW	ACC0_DR0	ED	RW
DCB03DR2	2E	RW	TMP_DR2	6E	RW	ACC1_DR3	AE	RW	ACC0_DR3	EE	RW
DCB03CR0	2F	#	TMP_DR3	6F	RW	ACC1_DR2	AF	RW	ACC0_DR2	EF	RW
	30		ACB00CR3	70	RW	RDI0RI	B0	RW		F0	
	31		ACB00CR0	71	RW	RDI0SYN	B1	RW		F1	
	32		ACB00CR1	72	RW	RDI0IS	B2	RW		F2	
	33		ACB00CR2	73	RW	RDI0LT0	B3	RW		F3	
	34		ACB01CR3	74	RW	RDI0LT1	B4	RW		F4	
	35		ACB01CR0	75	RW	RDI0RO0	B5	RW		F5	
	36		ACB01CR1	76	RW	RDI0RO1	B6	RW		F6	
	37		ACB01CR2	77	RW		B7		CPU_F	F7	RL
	38			78			B8			F8	
	39			79			B9			F9	
	3A			7A			BA			FA	
	3B			7B			BB			FB	
	3C			7C			BC			FC	
	3D			7D			BD		DAC_D	FD	RW
	3E			7E			BE		CPU_SCR1	FE	#
	3F			7F			BF		CPU_SCR0	FF	#

Blank fields are Reserved and should not be accessed. # Access is bit specific.

Register Map Bank 1 Table: Configuration Space

Name	Addr (1,Hex)	Access	Name	Addr (1,Hex)	Access	Name	Addr (1,Hex)	Access	Name	Addr (1,Hex)	Access
PRT0DM0	00	RW	PMA0_WA	40	RW	ASC10CR0	80	RW	USBIO_CR2	C0	RW
PRT0DM1	01	RW	PMA1_WA	41	RW	ASC10CR1	81	RW	USB_CR1	C1	#
PRT0IC0	02	RW	PMA2_WA	42	RW	ASC10CR2	82	RW			
PRT0IC1	03	RW	PMA3_WA	43	RW	ASC10CR3	83	RW			
PRT1DM0	04	RW	PMA4_WA	44	RW	ASD11CR0	84	RW	EP1_CR0	C4	#
PRT1DM1	05	RW	PMA5_WA	45	RW	ASD11CR1	85	RW	EP2_CR0	C5	#
PRT1IC0	06	RW	PMA6_WA	46	RW	ASD11CR2	86	RW	EP3_CR0	C6	#
PRT1IC1	07	RW	PMA7_WA	47	RW	ASD11CR3	87	RW	EP4_CR0	C7	#
PRT2DM0	08	RW		48			88			C8	
PRT2DM1	09	RW		49			89			C9	
PRT2IC0	0A	RW		4A			8A			CA	
PRT2IC1	0B	RW		4B			8B			CB	
PRT3DM0	0C	RW		4C			8C			CC	
PRT3DM1	0D	RW		4D			8D			CD	
PRT3IC0	0E	RW		4E			8E			CE	
PRT3IC1	0F	RW		4F			8F			CF	
PRT4DM0	10	RW	PMA0_RA	50	RW		90		GDI_O_IN	D0	RW
PRT4DM1	11	RW	PMA1_RA	51	RW	ASD20CR1	91	RW	GDI_E_IN	D1	RW
PRT4IC0	12	RW	PMA2_RA	52	RW	ASD20CR2	92	RW	GDI_O_OU	D2	RW
PRT4IC1	13	RW	PMA3_RA	53	RW	ASD20CR3	93	RW	GDI_E_OU	D3	RW
PRT5DM0	14	RW	PMA4_RA	54	RW	ASC21CR0	94	RW		D4	
PRT5DM1	15	RW	PMA5_RA	55	RW	ASC21CR1	95	RW		D5	
PRT5IC0	16	RW	PMA6_RA	56	RW	ASC21CR2	96	RW		D6	
PRT5IC1	17	RW	PMA7_RA	57	RW	ASC21CR3	97	RW		D7	
	18			58			98		MUX_CR0	D8	RW
	19			59			99		MUX_CR1	D9	RW
	1A			5A			9A		MUX_CR2	DA	RW
	1B			5B			9B		MUX_CR3	DB	RW
PRT7DM0	1C	RW		5C			9C			DC	
PRT7DM1	1D	RW		5D			9D		OSC_GO_EN	DD	RW
PRT7IC0	1E	RW		5E			9E		OSC_CR4	DE	RW
PRT7IC1	1F	RW		5F			9F		OSC_CR3	DF	RW
DBB00FN	20	RW	CLK_CR0	60	RW		A0		OSC_CR0	E0	RW
DBB00IN	21	RW	CLK_CR1	61	RW		A1		OSC_CR1	E1	RW
DBB00OU	22	RW	ABF_CR0	62	RW		A2		OSC_CR2	E2	RW
	23		AMD_CR0	63	RW		A3		VLT_CR	E3	RW
DBB01FN	24	RW	CMP_GO_EN	64	RW		A4		VLT_CMP	E4	R
DBB01IN	25	RW	CMP_GO_EN1	65	RW		A5			E5	
DBB01OU	26	RW	AMD_CR1	66	RW		A6			E6	
	27		ALT_CR0	67	RW		A7			E7	
DCB02FN	28	RW		68			A8		IMO_TR	E8	W
DCB02IN	29	RW		69			A9		ILO_TR	E9	W
DCB02OU	2A	RW		6A			AA		BDG_TR	EA	RW
	2B			6B			AB		ECO_TR	EB	W
DCB03FN	2C	RW	TMP_DR0	6C	RW		AC		MUX_CR4	EC	RW
DCB03IN	2D	RW	TMP_DR1	6D	RW		AD		MUX_CR5	ED	RW
DCB03OU	2E	RW	TMP_DR2	6E	RW		AE			EE	
	2F		TMP_DR3	6F	RW		AF			EF	
	30		ACB00CR3	70	RW	RDI0RI	B0	RW		F0	
	31		ACB00CR0	71	RW	RDI0SYN	B1	RW		F1	
	32		ACB00CR1	72	RW	RDI0IS	B2	RW		F2	
	33		ACB00CR2	73	RW	RDI0LT0	B3	RW		F3	
	34		ACB01CR3	74	RW	RDI0LT1	B4	RW		F4	
	35		ACB01CR0	75	RW	RDI0RO0	B5	RW		F5	
	36		ACB01CR1	76	RW	RDI0RO1	B6	RW		F6	
	37		ACB01CR2	77	RW		B7		CPU_F	F7	RL
	38			78			B8			F8	
	39			79			B9			F9	
	3A			7A			BA			FA	
	3B			7B			BB			FB	
	3C			7C			BC			FC	
	3D			7D			BD		DAC_CR	FD	RW
	3E			7E			BE		CPU_SCR1	FE	#
	3F			7F			BF		CPU_SCR0	FF	#

Blank fields are Reserved and should not be accessed.

Access is bit specific.

3. Electrical Specifications



This chapter presents the DC and AC electrical specifications of the CY8C24x94 PSoC device family. For the most up to date electrical specifications, confirm that you have the most recent data sheet by going to the web at <http://www.cypress.com/psoc>.

Specifications are valid for $-40^{\circ}\text{C} \leq T_A \leq 85^{\circ}\text{C}$ and $T_J \leq 100^{\circ}\text{C}$, except where noted. Specifications for devices running at greater than 12 MHz are valid for $-40^{\circ}\text{C} \leq T_A \leq 70^{\circ}\text{C}$ and $T_J \leq 82^{\circ}\text{C}$.

Figure 3-1. Voltage versus CPU Frequency

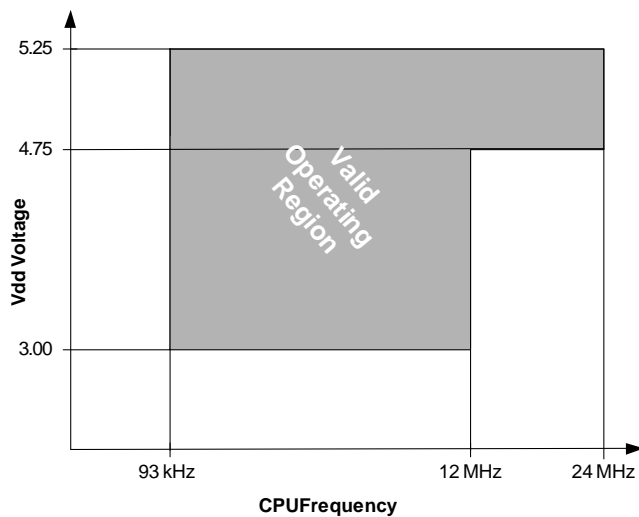

The following table lists the units of measure that are used in this chapter.

Table 3-1: Units of Measure

Symbol	Unit of Measure	Symbol	Unit of Measure
°C	degree Celsius	μW	microwatts
dB	decibels	mA	milli-ampere
fF	femto farad	ms	milli-second
Hz	hertz	mV	milli-volts
KB	1024 bytes	nA	nanoampere
Kbit	1024 bits	ns	nanosecond
kHz	kilohertz	nV	nanovolts
kΩ	kilohm	Ω	ohm
MHz	megahertz	pA	picoampere
MΩ	megaohm	pF	picofarad
μA	microampere	pp	peak-to-peak
μF	microfarad	ppm	parts per million
μH	microhenry	ps	picosecond
μs	microsecond	sps	samples per second
μV	microvolts	σ	sigma: one standard deviation
μVrms	microvolts root-mean-square	V	volts

3.1 Absolute Maximum Ratings

Table 3-2. Absolute Maximum Ratings

Symbol	Description	Min	Typ	Max	Units	Notes
T _{STG}	Storage Temperature	-55	25	+100	°C	Higher storage temperatures will reduce data retention time. Recommended storage temperature is +25°C ± 25°C. Extended duration storage temperatures above 65°C will degrade reliability.
T _A	Ambient Temperature with Power Applied	-40	–	+85	°C	
V _{DD}	Supply Voltage on V _{DD} Relative to V _{SS}	-0.5	–	+6.0	V	
V _{IO}	DC Input Voltage	V _{SS} - 0.5	–	V _{DD} + 0.5	V	
V _{IO2}	DC Voltage Applied to Tri-state	V _{SS} - 0.5	–	V _{DD} + 0.5	V	
I _{MIO}	Maximum Current into any Port Pin	-25	–	+50	mA	
I _{MAIO}	Maximum Current into any Port Pin Configured as Analog Driver	-50	–	+50	mA	
ESD	Electro Static Discharge Voltage	2000	–	–	V	Human Body Model ESD.
LU	Latch-up Current	–	–	200	mA	

3.2 Operating Temperature

Table 3-3. Operating Temperature

Symbol	Description	Min	Typ	Max	Units	Notes
T _A	Ambient Temperature	-40	–	+85	°C	
T _{AUSB}	Ambient Temperature using USB	-10	–	+85	°C	
T _J	Junction Temperature	-40	–	+100	°C	The temperature rise from ambient to junction is package specific. See "Thermal Impedance" on page 42. The user must limit the power consumption to comply with this requirement.

3.3 DC Electrical Characteristics

3.3.1 DC Chip-Level Specifications

The following table lists guaranteed maximum and minimum specifications for the voltage and temperature ranges: 4.75V to 5.25V and -40°C ≤ T_A ≤ 85°C, or 3.0V to 3.6V and -40°C ≤ T_A ≤ 85°C, respectively. Typical parameters apply to 5V and 3.3V at 25°C and are for design guidance only.

Table 3-4. DC Chip-Level Specifications

Symbol	Description	Min	Typ	Max	Units	Notes
V _{DD}	Supply Voltage	3.0	–	5.25	V	See DC POR and LVD specifications, Table 3-15 on page 29.
I _{DD5}	Supply Current, IMO = 24 MHz (5V)	–	14	27	mA	Conditions are V _{DD} = 5.0V, T _A = 25 °C, CPU = 3 MHz, SYSCLK doubler disabled, VC1 = 1.5 MHz, VC2 = 93.75 kHz, VC3 = 93.75 kHz, analog power = off.
I _{DD3}	Supply Current, IMO = 24 MHz (3.3V)	–	8	14	mA	Conditions are V _{DD} = 3.3V, T _A = 25 °C, CPU = 3 MHz, SYSCLK doubler disabled, VC1 = 1.5 MHz, VC2 = 93.75 kHz, VC3 = 0.367 kHz, analog power = off.
I _{SB}	Sleep (Mode) Current with POR, LVD, Sleep Timer, and WDT. ^a	–	3	6.5	µA	Conditions are with internal slow speed oscillator, V _{DD} = 3.3V, -40 °C ≤ T _A ≤ 55 °C, analog power = off.
I _{SBH}	Sleep (Mode) Current with POR, LVD, Sleep Timer, and WDT at high temperature. ^a	–	4	25	µA	Conditions are with internal slow speed oscillator, V _{DD} = 3.3V, 55 °C < T _A ≤ 85 °C, analog power = off.

a. Standby current includes all functions (POR, LVD, WDT, Sleep Time) needed for reliable system operation. This should be compared with devices that have similar functions enabled.

3.3.2 DC General Purpose IO Specifications

The following table lists guaranteed maximum and minimum specifications for the voltage and temperature ranges: 4.75V to 5.25V and $-40^{\circ}\text{C} \leq T_A \leq 85^{\circ}\text{C}$, or 3.0V to 3.6V and $-40^{\circ}\text{C} \leq T_A \leq 85^{\circ}\text{C}$, respectively. Typical parameters apply to 5V and 3.3V at 25°C and are for design guidance only.

Table 3-5. DC GPIO Specifications

Symbol	Description	Min	Typ	Max	Units	Notes
R _{PU}	Pull-Up Resistor	4	5.6	8	kΩ	
R _{PD}	Pull-Down Resistor	4	5.6	8	kΩ	
V _{OH}	High Output Level	V _{dd} - 1.0	–	–	V	I _{OH} = 10 mA, V _{dd} = 4.75 to 5.25V (8 total loads, 4 on even port pins (for example, P0[2], P1[4]), 4 on odd port pins (for example, P0[3], P1[5])). 80 mA maximum combined IOH budget.
V _{OL}	Low Output Level	–	–	0.75	V	I _{OL} = 25 mA, V _{dd} = 4.75 to 5.25V (8 total loads, 4 on even port pins (for example, P0[2], P1[4]), 4 on odd port pins (for example, P0[3], P1[5])). 200 mA maximum combined IOL budget.
V _{IL}	Input Low Level	–	–	0.8	V	V _{dd} = 3.0 to 5.25.
V _{IH}	Input High Level	2.1	–	–	V	V _{dd} = 3.0 to 5.25.
V _H	Input Hysteresis	–	60	–	mV	
I _{IL}	Input Leakage (Absolute Value)	–	1	–	nA	Gross tested to 1 μA.
C _{IN}	Capacitive Load on Pins as Input	–	3.5	10	pF	Package and pin dependent. Temp = 25°C.
C _{OUT}	Capacitive Load on Pins as Output	–	3.5	10	pF	Package and pin dependent. Temp = 25°C.

3.3.3 DC Full-Speed USB Specifications

The following table lists guaranteed maximum and minimum specifications for the voltage and temperature ranges: 4.75V to 5.25V and $-10^{\circ}\text{C} \leq T_A \leq 85^{\circ}\text{C}$, or 3.0V to 3.6V and $-10^{\circ}\text{C} \leq T_A \leq 85^{\circ}\text{C}$, respectively. Typical parameters apply to 5V and 3.3V at 25°C and are for design guidance only.

Table 3-6. DC Full-Speed (12 Mbps) USB Specifications

Symbol	Description	Min	Typ	Max	Units	Notes
USB Interface						
V _{DI}	Differential Input Sensitivity	0.2	–	–	V	(D+) - (D-)
V _{CM}	Differential Input Common Mode Range	0.8	–	2.5	V	
V _{SE}	Single Ended Receiver Threshold	0.8	–	2.0	V	
C _{IN}	Transceiver Capacitance	–	–	20	pF	
I _{IO}	High-Z State Data Line Leakage	-10	–	10	μA	0V < V _{IN} < 3.3V.
R _{EXT}	External USB Series Resistor	23	–	25	Ω	In series with each USB pin.
V _{UOH}	Static Output High, Driven	2.8	–	3.6	V	15 kΩ ± 5% to Ground. Internal pull-up enabled.
V _{UOHI}	Static Output High, Idle	2.7	–	3.6	V	15 kΩ ± 5% to Ground. Internal pull-up enabled.
V _{UOL}	Static Output Low	–	–	0.3	V	15 kΩ ± 5% to Ground. Internal pull-up enabled.
Z _O	USB Driver Output Impedance	28	–	44	Ω	Including R _{EXT} Resistor.
V _{CRS}	D+/D- Crossover Voltage	1.3	–	2.0	V	

3.3.4 DC Operational Amplifier Specifications

The following tables list guaranteed maximum and minimum specifications for the voltage and temperature ranges: 4.75V to 5.25V and $-40^{\circ}\text{C} \leq T_A \leq 85^{\circ}\text{C}$, or 3.0V to 3.6V and $-40^{\circ}\text{C} \leq T_A \leq 85^{\circ}\text{C}$, respectively. Typical parameters apply to 5V and 3.3V at 25°C and are for design guidance only.

The Operational Amplifier is a component of both the Analog Continuous Time PSoC blocks and the Analog Switched Capacitor PSoC blocks. The guaranteed specifications are measured in the Analog Continuous Time PSoC block.

Table 3-7. 5V DC Operational Amplifier Specifications

Symbol	Description	Min	Typ	Max	Units	Notes
V _{OSOA}	Input Offset Voltage (absolute value)					
	Power = Low, Opamp Bias = High	–	1.6	10	mV	
	Power = Medium, Opamp Bias = High	–	1.3	8	mV	
	Power = High, Opamp Bias = High	–	1.2	7.5	mV	
TCV _{OSOA}	Average Input Offset Voltage Drift	–	7.0	35.0	$\mu\text{V}/^{\circ}\text{C}$	
I _{EBOA}	Input Leakage Current (Port 0 Analog Pins)	–	20	–	pA	Gross tested to 1 μA .
C _{I_{NOA}}	Input Capacitance (Port 0 Analog Pins)	–	4.5	9.5	pF	Package and pin dependent. Temp = 25°C .
V _{CMOA}	Common Mode Voltage Range	0.0	–	V _{dd}	V	The common-mode input voltage range is measured through an analog output buffer. The specification includes the limitations imposed by the characteristics of the analog output buffer.
	Common Mode Voltage Range (high power or high opamp bias)	0.5	–	V _{dd} - 0.5		
G _{OLOA}	Open Loop Gain		–	–	dB	
	Power = Low, Opamp Bias = High	60				
	Power = Medium, Opamp Bias = High	60				
	Power = High, Opamp Bias = High	80				
V _{O_{HIGH}OA}	High Output Voltage Swing (internal signals)					
	Power = Low, Opamp Bias = High	V _{dd} - 0.2	–	–	V	
	Power = Medium, Opamp Bias = High	V _{dd} - 0.2	–	–	V	
	Power = High, Opamp Bias = High	V _{dd} - 0.5	–	–	V	
V _{O_{LOW}OA}	Low Output Voltage Swing (internal signals)					
	Power = Low, Opamp Bias = High	–	–	0.2	V	
	Power = Medium, Opamp Bias = High	–	–	0.2	V	
	Power = High, Opamp Bias = High	–	–	0.5	V	
I _{SOA}	Supply Current (including associated AGND buffer)					
	Power = Low, Opamp Bias = Low	–	400	800	μA	
	Power = Low, Opamp Bias = High	–	500	900	μA	
	Power = Medium, Opamp Bias = Low	–	800	1000	μA	
	Power = Medium, Opamp Bias = High	–	1200	1600	μA	
	Power = High, Opamp Bias = Low	–	2400	3200	μA	
	Power = High, Opamp Bias = High	–	4600	6400	μA	
PSRR _{OA}	Supply Voltage Rejection Ratio	65	80	–	dB	V _{ss} \leq VIN \leq (V _{dd} - 2.25) or (V _{dd} - 1.25V) \leq VIN \leq V _{dd} .

Table 3-8. 3.3V DC Operational Amplifier Specifications

Symbol	Description	Min	Typ	Max	Units	Notes
V _O SOA	Input Offset Voltage (absolute value)					
	Power = Low, Opamp Bias = High	–	1.65	10	mV	
	Power = Medium, Opamp Bias = High High Power is 5 Volts Only	–	1.32	8	mV	
TCV _O SOA	Average Input Offset Voltage Drift	–	7.0	35.0	μV/°C	
I _E BOA	Input Leakage Current (Port 0 Analog Pins)	–	20	–	pA	Gross tested to 1 μA.
C _I NOA	Input Capacitance (Port 0 Analog Pins)	–	4.5	9.5	pF	Package and pin dependent. Temp = 25°C.
V _{CM} OA	Common Mode Voltage Range	0.2	–	V _{DD} - 0.2	V	The common-mode input voltage range is measured through an analog output buffer. The specification includes the limitations imposed by the characteristics of the analog output buffer.
G _O LOA	Open Loop Gain		–	–	dB	
	Power = Low, Opamp Bias = Low	60				
	Power = Medium, Opamp Bias = Low Power = High, Opamp Bias = Low	60 80				
V _O HIGHOA	High Output Voltage Swing (internal signals)					
	Power = Low, Opamp Bias = Low	V _{DD} - 0.2	–	–	V	
	Power = Medium, Opamp Bias = Low Power = High is 5V only	V _{DD} - 0.2 V _{DD} - 0.2	– –	– –	V V	
V _O LOWOA	Low Output Voltage Swing (internal signals)					
	Power = Low, Opamp Bias = Low	–	–	0.2	V	
	Power = Medium, Opamp Bias = Low Power = High, Opamp Bias = Low	– –	– –	0.2 0.2	V V	
I _S OA	Supply Current (including associated AGND buffer)					
	Power = Low, Opamp Bias = Low	–	400	800	μA	
	Power = Low, Opamp Bias = High	–	500	900	μA	
	Power = Medium, Opamp Bias = Low	–	800	1000	μA	
	Power = Medium, Opamp Bias = High	–	1200	1600	μA	
	Power = High, Opamp Bias = Low Power = High, Opamp Bias = High	– –	2400 4600	3200 6400	μA μA	
PSRR _{OA}	Supply Voltage Rejection Ratio	65	80	–	dB	V _{SS} ≤ V _{IN} ≤ (V _{DD} - 2.25) or (V _{DD} - 1.25V) ≤ V _{IN} ≤ V _{DD} .

3.3.5 DC Low Power Comparator Specifications

The following table lists guaranteed maximum and minimum specifications for the voltage and temperature ranges: 4.75V to 5.25V and -40°C ≤ T_A ≤ 85°C, 3.0V to 3.6V and -40°C ≤ T_A ≤ 85°C, or 2.4V to 3.0V and -40°C ≤ T_A ≤ 85°C, respectively. Typical parameters apply to 5V at 25°C and are for design guidance only.

Table 3-9. DC Low Power Comparator Specifications

Symbol	Description	Min	Typ	Max	Units	Notes
V _{REF} LPC	Low power comparator (LPC) reference voltage range	0.2	–	V _{DD} - 1	V	
I _S LPC	LPC supply current	–	10	40	μA	
V _O SLPC	LPC voltage offset	–	2.5	30	mV	

3.3.6 DC Analog Output Buffer Specifications

The following tables list guaranteed maximum and minimum specifications for the voltage and temperature ranges: 4.75V to 5.25V and $-40^{\circ}\text{C} \leq T_A \leq 85^{\circ}\text{C}$, or 3.0V to 3.6V and $-40^{\circ}\text{C} \leq T_A \leq 85^{\circ}\text{C}$, respectively. Typical parameters apply to 5V and 3.3V at 25°C and are for design guidance only.

Table 3-10. 5V DC Analog Output Buffer Specifications

Symbol	Description	Min	Typ	Max	Units	Notes
V_{OSOB}	Input Offset Voltage (Absolute Value)	–	3	12	mV	
TCV_{OSOB}	Average Input Offset Voltage Drift	–	+6	–	$\mu\text{V}/^{\circ}\text{C}$	
V_{CMOB}	Common-Mode Input Voltage Range	0.5	–	$V_{DD} - 1.0$	V	
R_{OUTOB}	Output Resistance Power = Low Power = High	– –	0.6 0.6	– –	Ω Ω	
$V_{OHIGHOB}$	High Output Voltage Swing (Load = 32 ohms to $V_{DD}/2$) Power = Low Power = High	$0.5 \times V_{DD} + 1.1$ $0.5 \times V_{DD} + 1.1$	– –	– –	V V	
V_{LOWOB}	Low Output Voltage Swing (Load = 32 ohms to $V_{DD}/2$) Power = Low Power = High	– –	– –	$0.5 \times V_{DD} - 1.3$ $0.5 \times V_{DD} - 1.3$	V V	
I_{SOB}	Supply Current Including Bias Cell (No Load) Power = Low Power = High	– –	1.1 2.6	5.1 8.8	mA mA	
$PSRR_{OB}$	Supply Voltage Rejection Ratio	53	64	–	dB	$(0.5 \times V_{DD} - 1.3) \leq V_{OUT} \leq (V_{DD} - 2.3)$.

Table 3-11. 3.3V DC Analog Output Buffer Specifications

Symbol	Description	Min	Typ	Max	Units	Notes
V_{OSOB}	Input Offset Voltage (Absolute Value)	–	3	12	mV	
TCV_{OSOB}	Average Input Offset Voltage Drift	–	+6	–	$\mu\text{V}/^{\circ}\text{C}$	
V_{CMOB}	Common-Mode Input Voltage Range	0.5	–	$V_{DD} - 1.0$	V	
R_{OUTOB}	Output Resistance Power = Low Power = High	– –	1 1	– –	Ω Ω	
$V_{OHIGHOB}$	High Output Voltage Swing (Load = 1K ohms to $V_{DD}/2$) Power = Low Power = High	$0.5 \times V_{DD} + 1.0$ $0.5 \times V_{DD} + 1.0$	– –	– –	V V	
V_{LOWOB}	Low Output Voltage Swing (Load = 1K ohms to $V_{DD}/2$) Power = Low Power = High	– –	– –	$0.5 \times V_{DD} - 1.0$ $0.5 \times V_{DD} - 1.0$	V V	
I_{SOB}	Supply Current Including Bias Cell (No Load) Power = Low Power = High	– –	0.8 2.0	2.0 4.3	mA mA	
$PSRR_{OB}$	Supply Voltage Rejection Ratio	34	64	–	dB	$(0.5 \times V_{DD} - 1.0) \leq V_{OUT} \leq (0.5 \times V_{DD} + 0.9)$.

3.3.7 DC Analog Reference Specifications

The following tables list guaranteed maximum and minimum specifications for the voltage and temperature ranges: 4.75V to 5.25V and $-40^{\circ}\text{C} \leq T_A \leq 85^{\circ}\text{C}$, or 3.0V to 3.6V and $-40^{\circ}\text{C} \leq T_A \leq 85^{\circ}\text{C}$, respectively. Typical parameters apply to 5V and 3.3V at 25°C and are for design guidance only.

The guaranteed specifications are measured through the Analog Continuous Time PSoC blocks. The power levels for AGND refer to the power of the Analog Continuous Time PSoC block. The power levels for RefHi and RefLo refer to the Analog Reference Control register. The limits stated for AGND include the offset error of the AGND buffer local to the Analog Continuous Time PSoC block. Reference control power is high.

Table 3-12. 5V DC Analog Reference Specifications

Symbol	Description	Min	Typ	Max	Units
BG	Bandgap Voltage Reference	1.28	1.30	1.32	V
–	AGND = $V_{dd}/2^a$	$V_{dd}/2 - 0.04$	$V_{dd}/2 - 0.01$	$V_{dd}/2 + 0.007$	V
–	AGND = $2 \times \text{BandGap}^a$	$2 \times \text{BG} - 0.048$	$2 \times \text{BG} - 0.030$	$2 \times \text{BG} + 0.024$	V
–	AGND = $P2[4] (P2[4] = V_{dd}/2)^a$	$P2[4] - 0.011$	$P2[4]$	$P2[4] + 0.011$	V
–	AGND = BandGap^a	$\text{BG} - 0.009$	$\text{BG} + 0.008$	$\text{BG} + 0.016$	V
–	AGND = $1.6 \times \text{BandGap}^a$	$1.6 \times \text{BG} - 0.022$	$1.6 \times \text{BG} - 0.010$	$1.6 \times \text{BG} + 0.018$	V
–	AGND Block to Block Variation (AGND = $V_{dd}/2$) ^a	-0.034	0.000	0.034	V
–	RefHi = $V_{dd}/2 + \text{BandGap}$	$V_{dd}/2 + \text{BG} - 0.10$	$V_{dd}/2 + \text{BG}$	$V_{dd}/2 + \text{BG} + 0.10$	V
–	RefHi = $3 \times \text{BandGap}$	$3 \times \text{BG} - 0.06$	$3 \times \text{BG}$	$3 \times \text{BG} + 0.06$	V
–	RefHi = $2 \times \text{BandGap} + P2[6] (P2[6] = 1.3V)$	$2 \times \text{BG} + P2[6] - 0.113$	$2 \times \text{BG} + P2[6] - 0.018$	$2 \times \text{BG} + P2[6] + 0.077$	V
–	RefHi = $P2[4] + \text{BandGap} (P2[4] = V_{dd}/2)$	$P2[4] + \text{BG} - 0.130$	$P2[4] + \text{BG} - 0.016$	$P2[4] + \text{BG} + 0.098$	V
–	RefHi = $P2[4] + P2[6] (P2[4] = V_{dd}/2, P2[6] = 1.3V)$	$P2[4] + P2[6] - 0.133$	$P2[4] + P2[6] - 0.016$	$P2[4] + P2[6] + 0.100$	V
–	RefHi = $3.2 \times \text{BandGap}$	$3.2 \times \text{BG} - 0.112$	$3.2 \times \text{BG}$	$3.2 \times \text{BG} + 0.076$	V
–	RefLo = $V_{dd}/2 - \text{BandGap}$	$V_{dd}/2 - \text{BG} - 0.04$	$V_{dd}/2 - \text{BG} + 0.024$	$V_{dd}/2 - \text{BG} + 0.04$	V
–	RefLo = BandGap	$\text{BG} - 0.06$	BG	$\text{BG} + 0.06$	V
–	RefLo = $2 \times \text{BandGap} - P2[6] (P2[6] = 1.3V)$	$2 \times \text{BG} - P2[6] - 0.084$	$2 \times \text{BG} - P2[6] + 0.025$	$2 \times \text{BG} - P2[6] + 0.134$	V
–	RefLo = $P2[4] - \text{BandGap} (P2[4] = V_{dd}/2)$	$P2[4] - \text{BG} - 0.056$	$P2[4] - \text{BG} + 0.026$	$P2[4] - \text{BG} + 0.107$	V
–	RefLo = $P2[4] - P2[6] (P2[4] = V_{dd}/2, P2[6] = 1.3V)$	$P2[4] - P2[6] - 0.057$	$P2[4] - P2[6] + 0.026$	$P2[4] - P2[6] + 0.110$	V

a. AGND tolerance includes the offsets of the local buffer in the PSoC block. Bandgap voltage is $1.3V \pm 0.02V$.

Table 3-13. 3.3V DC Analog Reference Specifications

Symbol	Description	Min	Typ	Max	Units
BG	Bandgap Voltage Reference	1.28	1.30	1.32	V
–	AGND = $V_{dd}/2^a$	$V_{dd}/2 - 0.03$	$V_{dd}/2 - 0.01$	$V_{dd}/2 + 0.005$	V
–	AGND = $2 \times \text{BandGap}^a$	Not Allowed			
–	AGND = $P2[4] (P2[4] = V_{dd}/2)$	$P2[4] - 0.008$	$P2[4] + 0.001$	$P2[4] + 0.009$	V
–	AGND = BandGap^a	$\text{BG} - 0.009$	$\text{BG} + 0.005$	$\text{BG} + 0.015$	V
–	AGND = $1.6 \times \text{BandGap}^a$	$1.6 \times \text{BG} - 0.027$	$1.6 \times \text{BG} - 0.010$	$1.6 \times \text{BG} + 0.018$	V
–	AGND Column to Column Variation (AGND = $V_{dd}/2$) ^a	-0.034	0.000	0.034	V
–	RefHi = $V_{dd}/2 + \text{BandGap}$	Not Allowed			
–	RefHi = $3 \times \text{BandGap}$	Not Allowed			
–	RefHi = $2 \times \text{BandGap} + P2[6] (P2[6] = 0.5V)$	Not Allowed			
–	RefHi = $P2[4] + \text{BandGap} (P2[4] = V_{dd}/2)$	Not Allowed			
–	RefHi = $P2[4] + P2[6] (P2[4] = V_{dd}/2, P2[6] = 0.5V)$	$P2[4] + P2[6] - 0.075$	$P2[4] + P2[6] - 0.009$	$P2[4] + P2[6] + 0.057$	V
–	RefHi = $3.2 \times \text{BandGap}$	Not Allowed			
–	RefLo = $V_{dd}/2 - \text{BandGap}$	Not Allowed			
–	RefLo = BandGap	Not Allowed			
–	RefLo = $2 \times \text{BandGap} - P2[6] (P2[6] = 0.5V)$	Not Allowed			
–	RefLo = $P2[4] - \text{BandGap} (P2[4] = V_{dd}/2)$	Not Allowed			
–	RefLo = $P2[4] - P2[6] (P2[4] = V_{dd}/2, P2[6] = 0.5V)$	$P2[4] - P2[6] - 0.048$	$P2[4] - P2[6] + 0.022$	$P2[4] - P2[6] + 0.092$	V

a. AGND tolerance includes the offsets of the local buffer in the PSoC block. Bandgap voltage is $1.3V \pm 0.02V$.

3.3.8 DC Analog PSoC Block Specifications

The following table lists guaranteed maximum and minimum specifications for the voltage and temperature ranges: 4.75V to 5.25V and $-40^{\circ}\text{C} \leq T_A \leq 85^{\circ}\text{C}$, or 3.0V to 3.6V and $-40^{\circ}\text{C} \leq T_A \leq 85^{\circ}\text{C}$, respectively. Typical parameters apply to 5V and 3.3V at 25°C and are for design guidance only.

Table 3-14. DC Analog PSoC Block Specifications

Symbol	Description	Min	Typ	Max	Units	Notes
R _{CT}	Resistor Unit Value (Continuous Time)	–	12.2	–	kΩ	
C _{SC}	Capacitor Unit Value (Switched Capacitor)	–	80	–	fF	

3.3.9 DC POR and LVD Specifications

The following table lists guaranteed maximum and minimum specifications for the voltage and temperature ranges: 4.75V to 5.25V and $-40^{\circ}\text{C} \leq T_A \leq 85^{\circ}\text{C}$, or 3.0V to 3.6V and $-40^{\circ}\text{C} \leq T_A \leq 85^{\circ}\text{C}$, respectively. Typical parameters apply to 5V or 3.3V at 25°C and are for design guidance only.

Note The bits PORLEV and VM in the table below refer to bits in the VLT_CR register. See the *PSoC Mixed-Signal Array Technical Reference Manual* for more information on the VLT_CR register.

Table 3-15. DC POR and LVD Specifications

Symbol	Description	Min	Typ	Max	Units	Notes
V _{PPOR0R}	V _{DD} Value for PPOR Trip (positive ramp) PORLEV[1:0] = 00b	–	2.91	–	V	
V _{PPOR1R}	PORLEV[1:0] = 01b	–	4.39	–	V	
V _{PPOR2R}	PORLEV[1:0] = 10b	–	4.55	–	V	
V _{PPOR0}	V _{DD} Value for PPOR Trip (negative ramp) PORLEV[1:0] = 00b	–	2.82	–	V	
V _{PPOR1}	PORLEV[1:0] = 01b	–	4.39	–	V	
V _{PPOR2}	PORLEV[1:0] = 10b	–	4.55	–	V	
V _{PH0}	PPOR Hysteresis PORLEV[1:0] = 00b	–	92	–	mV	
V _{PH1}	PORLEV[1:0] = 01b	–	0	–	mV	
V _{PH2}	PORLEV[1:0] = 10b	–	0	–	mV	
V _{LVD0}	V _{DD} Value for LVD Trip VM[2:0] = 000b	2.86	2.92	2.98 ^a	V	
V _{LVD1}	VM[2:0] = 001b	2.96	3.02	3.08	V	
V _{LVD2}	VM[2:0] = 010b	3.07	3.13	3.20	V	
V _{LVD3}	VM[2:0] = 011b	3.92	4.00	4.08	V	
V _{LVD4}	VM[2:0] = 100b	4.39	4.48	4.57	V	
V _{LVD5}	VM[2:0] = 101b	4.55	4.64	4.74 ^b	V	
V _{LVD6}	VM[2:0] = 110b	4.63	4.73	4.82	V	
V _{LVD7}	VM[2:0] = 111b	4.72	4.81	4.91	V	

a. Always greater than 50 mV above PPOR (PORLEV = 00) for falling supply.

b. Always greater than 50 mV above PPOR (PORLEV = 10) for falling supply.

3.3.10 DC Programming Specifications

The following table lists guaranteed maximum and minimum specifications for the voltage and temperature ranges: 4.75V to 5.25V and $-40^{\circ}\text{C} \leq T_A \leq 85^{\circ}\text{C}$, or 3.0V to 3.6V and $-40^{\circ}\text{C} \leq T_A \leq 85^{\circ}\text{C}$, respectively. Typical parameters apply to 5V and 3.3V at 25°C and are for design guidance only.

Table 3-16. DC Programming Specifications

Symbol	Description	Min	Typ	Max	Units	Notes
I_{DDP}	Supply Current During Programming or Verify	–	15	30	mA	
V_{ILP}	Input Low Voltage During Programming or Verify	–	–	0.8	V	
V_{IHP}	Input High Voltage During Programming or Verify	2.1	–	–	V	
I_{ILP}	Input Current when Applying V_{ilp} to P1[0] or P1[1] During Programming or Verify	–	–	0.2	mA	Driving internal pull-down resistor.
I_{IHP}	Input Current when Applying V_{ihp} to P1[0] or P1[1] During Programming or Verify	–	–	1.5	mA	Driving internal pull-down resistor.
V_{OLV}	Output Low Voltage During Programming or Verify	–	–	$V_{SS} + 0.75$	V	
V_{OHV}	Output High Voltage During Programming or Verify	$V_{DD} - 1.0$	–	V_{DD}	V	
Flash _{ENPB}	Flash Endurance (per block)	50,000	–	–	–	Erase/write cycles per block.
Flash _{ENT}	Flash Endurance (total) ^a	1,800,000	–	–	–	Erase/write cycles.
Flash _{DR}	Flash Data Retention	10	–	–	Years	

- a. A maximum of 36 x 50,000 block endurance cycles is allowed. This may be balanced between operations on 36x1 blocks of 50,000 maximum cycles each, 36x2 blocks of 25,000 maximum cycles each, or 36x4 blocks of 12,500 maximum cycles each (to limit the total number of cycles to 36x50,000 and that no single block ever sees more than 50,000 cycles).

For the full industrial range, the user must employ a temperature sensor user module (FlashTemp) and feed the result to the temperature argument before writing. Refer to the Flash APIs Application Note AN2015 at <http://www.cypress.com> under Application Notes for more information.

3.4 AC Electrical Characteristics

3.4.1 AC Chip-Level Specifications

The following table lists guaranteed maximum and minimum specifications for the voltage and temperature ranges: 4.75V to 5.25V and $-40^{\circ}\text{C} \leq T_A \leq 85^{\circ}\text{C}$, or 3.0V to 3.6V and $-40^{\circ}\text{C} \leq T_A \leq 85^{\circ}\text{C}$, respectively. Typical parameters apply to 5V and 3.3V at 25°C and are for design guidance only.

Table 3-17. AC Chip-Level Specifications

Symbol	Description	Min	Typ	Max	Units	Notes
F _{IMO245V}	Internal Main Oscillator Frequency for 24 MHz (5V)	23.04	24	24.96 ^{a,b}	MHz	Trimmed for 5V operation using factory trim values.
F _{IMO243V}	Internal Main Oscillator Frequency for 24 MHz (3.3V)	22.08	24	25.92 ^{b,c}	MHz	Trimmed for 3.3V operation using factory trim values.
F _{IMOUSB5V}	Internal Main Oscillator Frequency with USB (5V) Frequency locking enabled and USB traffic present.	23.94	24	24.06 ^b	MHz	$-10^{\circ}\text{C} \leq T_A \leq 85^{\circ}\text{C}$ $4.35 \leq V_{dd} \leq 5.15$
F _{IMOUSB3V}	Internal Main Oscillator Frequency with USB (3.3V) Frequency locking enabled and USB traffic present.	23.94	24	24.06 ^b	MHz	$-0^{\circ}\text{C} \leq T_A \leq 70^{\circ}\text{C}$ $3.15 \leq V_{dd} \leq 3.45$
F _{CPU1}	CPU Frequency (5V Nominal)	0.93	24	24.96 ^{a,b}	MHz	
F _{CPU2}	CPU Frequency (3.3V Nominal)	0.93	12	12.96 ^{b,c}	MHz	
F _{BLK5}	Digital PSoC Block Frequency (5V Nominal)	0	48	49.92 ^{a,b,d}	MHz	Refer to the AC Digital Block Specifications.
F _{BLK3}	Digital PSoC Block Frequency (3.3V Nominal)	0	24	25.92 ^{b,d}	MHz	
F _{32K1}	Internal Low Speed Oscillator Frequency	15	32	64	kHz	
Jitter32k	32 kHz Period Jitter	–	100		ns	
Step24M	24 MHz Trim Step Size	–	50	–	kHz	
F _{out48M}	48 MHz Output Frequency	46.08	48.0	49.92 ^{a,c}	MHz	Trimmed. Utilizing factory trim values.
Jitter24M1	24 MHz Period Jitter (IMO) Peak-to-Peak	–	300		ps	
F _{MAX}	Maximum frequency of signal on row input or row output.	–	–	12.96	MHz	
T _{RAMP}	Supply Ramp Time	0	–	–	μs	

- a. 4.75V < V_{dd} < 5.25V.
- b. Accuracy derived from Internal Main Oscillator with appropriate trim for V_{dd} range.
- c. 3.0V < V_{dd} < 3.6V. See Application Note AN2012 "Adjusting PSoC Microcontroller Trims for Dual Voltage-Range Operation" for information on trimming for operation at 3.3V.
- d. See the individual user module data sheets for information on maximum frequencies for user modules.

Figure 3-2. 24 MHz Period Jitter (IMO) Timing Diagram

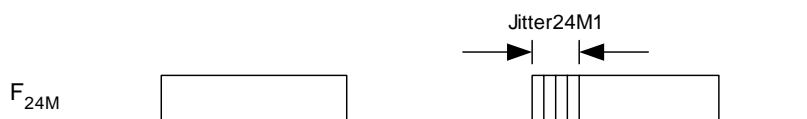

3.4.2 AC General Purpose IO Specifications

The following table lists guaranteed maximum and minimum specifications for the voltage and temperature ranges: 4.75V to 5.25V and $-40^{\circ}\text{C} \leq T_A \leq 85^{\circ}\text{C}$, or 3.0V to 3.6V and $-40^{\circ}\text{C} \leq T_A \leq 85^{\circ}\text{C}$, respectively. Typical parameters apply to 5V and 3.3V at 25°C and are for design guidance only.

Table 3-18. AC GPIO Specifications

Symbol	Description	Min	Typ	Max	Units	Notes
F_{GPIO}	GPIO Operating Frequency	0	–	12	MHz	Normal Strong Mode
T_{RiseF}	Rise Time, Normal Strong Mode, Cloud = 50 pF	3	–	18	ns	Vdd = 4.5 to 5.25V, 10% - 90%
T_{FallF}	Fall Time, Normal Strong Mode, Cloud = 50 pF	2	–	18	ns	Vdd = 4.5 to 5.25V, 10% - 90%
T_{RiseS}	Rise Time, Slow Strong Mode, Cloud = 50 pF	10	27	–	ns	Vdd = 3 to 5.25V, 10% - 90%
T_{FallS}	Fall Time, Slow Strong Mode, Cloud = 50 pF	10	22	–	ns	Vdd = 3 to 5.25V, 10% - 90%

Figure 3-3. GPIO Timing Diagram

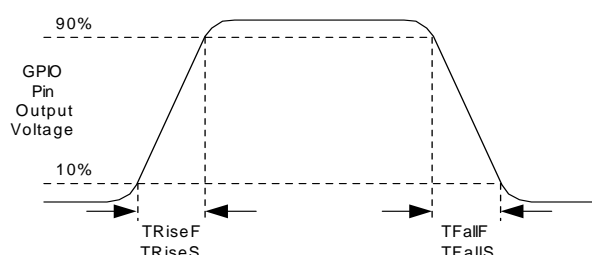

3.4.3 AC Full-Speed USB Specifications

The following table lists guaranteed maximum and minimum specifications for the voltage and temperature ranges: 4.75V to 5.25V and $-10^{\circ}\text{C} \leq T_A \leq 85^{\circ}\text{C}$, or 3.0V to 3.6V and $-10^{\circ}\text{C} \leq T_A \leq 85^{\circ}\text{C}$, respectively. Typical parameters apply to 5V and 3.3V at 25°C and are for design guidance only.

Table 3-19. AC Full-Speed (12 Mbps) USB Specifications

Symbol	Description	Min	Typ	Max	Units	Notes
T_{RFS}	Transition Rise Time	4	–	20	ns	For 50 pF load.
T_{FSS}	Transition Fall Time	4	–	20	ns	For 50 pF load.
T_{RFMFS}	Rise/Fall Time Matching: ($T_{\text{R}}/T_{\text{F}}$)	90	–	111	%	For 50 pF load.
T_{DRATEFS}	Full-Speed Data Rate	12 - 0.25%	12	12 + 0.25%	Mbps	

3.4.4 AC Operational Amplifier Specifications

The following tables list guaranteed maximum and minimum specifications for the voltage and temperature ranges: 4.75V to 5.25V and $-40^{\circ}\text{C} \leq T_A \leq 85^{\circ}\text{C}$, or 3.0V to 3.6V and $-40^{\circ}\text{C} \leq T_A \leq 85^{\circ}\text{C}$, respectively. Typical parameters apply to 5V and 3.3V at 25°C and are for design guidance only.

Settling times, slew rates, and gain bandwidth are based on the Analog Continuous Time PSoC block.

Power = High and Opamp Bias = High is not supported at 3.3V.

Table 3-20. 5V AC Operational Amplifier Specifications

Symbol	Description	Min	Typ	Max	Units	Notes
T _{ROA}	Rising Settling Time from 80% of ΔV to 0.1% of ΔV (10 pF load, Unity Gain)					
	Power = Low, Opamp Bias = Low	–	–	3.9	μs	
	Power = Medium, Opamp Bias = High	–	–	0.72	μs	
T _{SOA}	Falling Settling Time from 20% of ΔV to 0.1% of ΔV (10 pF load, Unity Gain)					
	Power = Low, Opamp Bias = Low	–	–	5.9	μs	
	Power = Medium, Opamp Bias = High	–	–	0.92	μs	
SR _{ROA}	Rising Slew Rate (20% to 80%)(10 pF load, Unity Gain)					
	Power = Low, Opamp Bias = Low	0.15	–	–	V/ μs	
	Power = Medium, Opamp Bias = High	1.7	–	–	V/ μs	
SR _{FOA}	Falling Slew Rate (20% to 80%)(10 pF load, Unity Gain)					
	Power = Low, Opamp Bias = Low	0.01	–	–	V/ μs	
	Power = Medium, Opamp Bias = High	0.5	–	–	V/ μs	
BW _{OA}	Gain Bandwidth Product					
	Power = Low, Opamp Bias = Low	0.75	–	–	MHz	
	Power = Medium, Opamp Bias = High	3.1	–	–	MHz	
E _{NOA}	Noise at 1 kHz (Power = Medium, Opamp Bias = High)	–	100	–	nV/rt-Hz	

Table 3-21. 3.3V AC Operational Amplifier Specifications

Symbol	Description	Min	Typ	Max	Units	Notes
T _{ROA}	Rising Settling Time from 80% of ΔV to 0.1% of ΔV (10 pF load, Unity Gain)					
	Power = Low, Opamp Bias = Low	–	–	3.92	μs	
T _{SOA}	Falling Settling Time from 20% of ΔV to 0.1% of ΔV (10 pF load, Unity Gain)					
	Power = Low, Opamp Bias = Low	–	–	5.41	μs	
SR _{ROA}	Rising Slew Rate (20% to 80%)(10 pF load, Unity Gain)					
	Power = Low, Opamp Bias = Low	0.31	–	–	V/ μs	
SR _{FOA}	Falling Slew Rate (20% to 80%)(10 pF load, Unity Gain)					
	Power = Low, Opamp Bias = Low	0.24	–	–	V/ μs	
BW _{OA}	Gain Bandwidth Product					
	Power = Low, Opamp Bias = Low	0.67	–	–	MHz	
E _{NOA}	Noise at 1 kHz (Power = Medium, Opamp Bias = High)	–	100	–	nV/rt-Hz	

When bypassed by a capacitor on P2[4], the noise of the analog ground signal distributed to each block is reduced by a factor of up to 5 (14 dB). This is at frequencies above the corner frequency defined by the on-chip 8.1k resistance and the external capacitor.

Figure 3-4. Typical AGND Noise with P2[4] Bypass

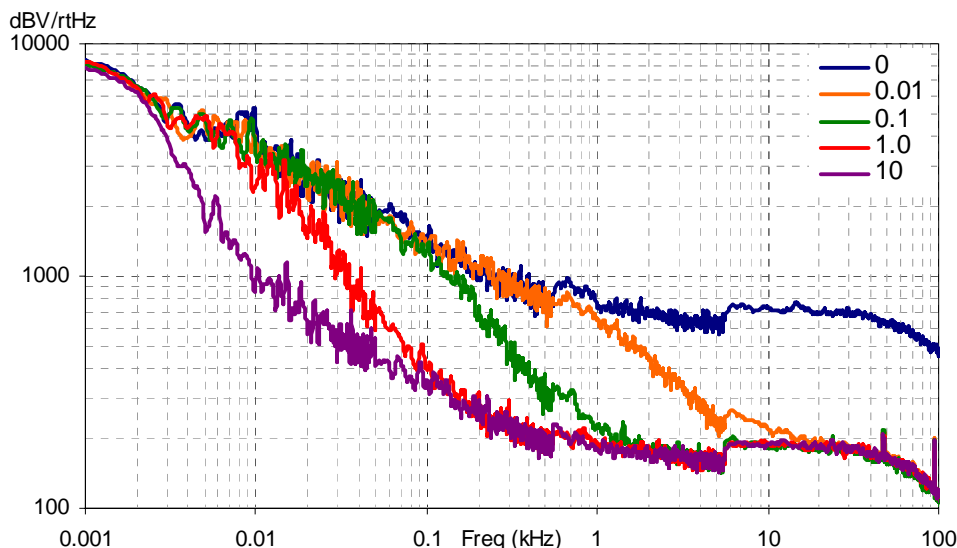

At low frequencies, the opamp noise is proportional to 1/f, power independent, and determined by device geometry. At high frequencies, increased power level reduces the noise spectrum level.

Figure 3-5. Typical Opamp Noise

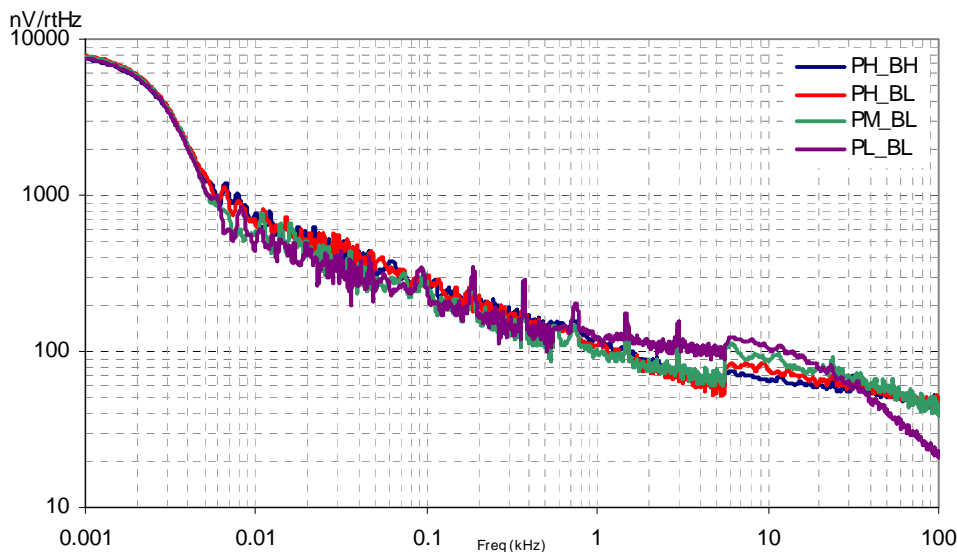

3.4.5 AC Low Power Comparator Specifications

The following table lists guaranteed maximum and minimum specifications for the voltage and temperature ranges: 4.75V to 5.25V and $-40^{\circ}\text{C} \leq T_A \leq 85^{\circ}\text{C}$, 3.0V to 3.6V and $-40^{\circ}\text{C} \leq T_A \leq 85^{\circ}\text{C}$, or 2.4V to 3.0V and $-40^{\circ}\text{C} \leq T_A \leq 85^{\circ}\text{C}$, respectively. Typical parameters apply to 5V at 25°C and are for design guidance only.

Table 3-22. AC Low Power Comparator Specifications

Symbol	Description	Min	Typ	Max	Units	Notes
T_{RLPC}	LPC response time	–	–	50	μs	≥ 50 mV overdrive comparator reference set within V_{REFLPC} .

3.4.6 AC Digital Block Specifications

The following table lists guaranteed maximum and minimum specifications for the voltage and temperature ranges: 4.75V to 5.25V and $-40^{\circ}\text{C} \leq T_A \leq 85^{\circ}\text{C}$, or 3.0V to 3.6V and $-40^{\circ}\text{C} \leq T_A \leq 85^{\circ}\text{C}$, respectively. Typical parameters apply to 5V and 3.3V at 25°C and are for design guidance only.

Table 3-23. AC Digital Block Specifications

Function	Description	Min	Typ	Max	Units	Notes
Timer	Capture Pulse Width	50 ^a	–	–	ns	
	Maximum Frequency, No Capture	–	–	49.92	MHz	4.75V < Vdd < 5.25V.
	Maximum Frequency, With Capture	–	–	25.92	MHz	
Counter	Enable Pulse Width	50 ^a	–	–	ns	
	Maximum Frequency, No Enable Input	–	–	49.92	MHz	4.75V < Vdd < 5.25V.
	Maximum Frequency, Enable Input	–	–	25.92	MHz	
Dead Band	Kill Pulse Width:					
	Asynchronous Restart Mode	20	–	–	ns	
	Synchronous Restart Mode	50 ^a	–	–	ns	
	Disable Mode	50 ^a	–	–	ns	
	Maximum Frequency	–	–	49.92	MHz	4.75V < Vdd < 5.25V.
CRCPRS (PRS Mode)	Maximum Input Clock Frequency	–	–	49.92	MHz	4.75V < Vdd < 5.25V.
CRCPRS (CRC Mode)	Maximum Input Clock Frequency	–	–	24.6	MHz	
SPIM	Maximum Input Clock Frequency	–	–	8.2	MHz	Maximum data rate at 4.1 MHz due to 2 x over clocking.
SPIS	Maximum Input Clock Frequency	–	–	4.1	MHz	
	Width of SS_ Negated Between Transmissions	50 ^a	–	–	ns	
Transmitter	Maximum Input Clock Frequency	–	–	24.6	MHz	Maximum data rate at 3.08 MHz due to 8 x over clocking.
Receiver	Maximum Input Clock Frequency	–	–	24.6	MHz	Maximum data rate at 3.08 MHz due to 8 x over clocking.

a. 50 ns minimum input pulse width is based on the input synchronizers running at 24 MHz (42 ns nominal period).

3.4.7 AC External Clock Specifications

The following tables list guaranteed maximum and minimum specifications for the voltage and temperature ranges: 4.75V to 5.25V and $-40^{\circ}\text{C} \leq T_A \leq 85^{\circ}\text{C}$, or 3.0V to 3.6V and $-40^{\circ}\text{C} \leq T_A \leq 85^{\circ}\text{C}$, respectively. Typical parameters apply to 5V and 3.3V at 25°C and are for design guidance only.

Table 3-24. AC External Clock Specifications

Symbol	Description	Min	Typ	Max	Units	Notes
F_{OSCEXT}	Frequency for USB Applications	23.94	24	24.06	MHz	
–	Duty Cycle	47	50	53	%	
–	Power up to IMO Switch	150	–	–	μs	

3.4.8 AC Analog Output Buffer Specifications

The following tables list guaranteed maximum and minimum specifications for the voltage and temperature ranges: 4.75V to 5.25V and $-40^{\circ}\text{C} \leq T_A \leq 85^{\circ}\text{C}$, or 3.0V to 3.6V and $-40^{\circ}\text{C} \leq T_A \leq 85^{\circ}\text{C}$, respectively. Typical parameters apply to 5V and 3.3V at 25°C and are for design guidance only.

Table 3-25. 5V AC Analog Output Buffer Specifications

Symbol	Description	Min	Typ	Max	Units	Notes
T _{ROB}	Rising Settling Time to 0.1%, 1V Step, 100pF Load					
	Power = Low	–	–	2.5	μs	
	Power = High	–	–	2.5	μs	
T _{SOB}	Falling Settling Time to 0.1%, 1V Step, 100pF Load					
	Power = Low	–	–	2.2	μs	
	Power = High	–	–	2.2	μs	
SR _{ROB}	Rising Slew Rate (20% to 80%), 1V Step, 100pF Load					
	Power = Low	0.65	–	–	V/μs	
	Power = High	0.65	–	–	V/μs	
SR _{FOB}	Falling Slew Rate (80% to 20%), 1V Step, 100pF Load					
	Power = Low	0.65	–	–	V/μs	
	Power = High	0.65	–	–	V/μs	
BW _{OBS}	Small Signal Bandwidth, 20mV _{pp} , 3dB BW, 100pF Load					
	Power = Low	0.8	–	–	MHz	
	Power = High	0.8	–	–	MHz	
BW _{OBS}	Large Signal Bandwidth, 1V _{pp} , 3dB BW, 100pF Load					
	Power = Low	300	–	–	kHz	
	Power = High	300	–	–	kHz	

Table 3-26. 3.3V AC Analog Output Buffer Specifications

Symbol	Description	Min	Typ	Max	Units	Notes
T _{ROB}	Rising Settling Time to 0.1%, 1V Step, 100pF Load					
	Power = Low	–	–	3.8	μs	
	Power = High	–	–	3.8	μs	
T _{SOB}	Falling Settling Time to 0.1%, 1V Step, 100pF Load					
	Power = Low	–	–	2.6	μs	
	Power = High	–	–	2.6	μs	
SR _{ROB}	Rising Slew Rate (20% to 80%), 1V Step, 100pF Load					
	Power = Low	0.5	–	–	V/μs	
	Power = High	0.5	–	–	V/μs	
SR _{FOB}	Falling Slew Rate (80% to 20%), 1V Step, 100pF Load					
	Power = Low	0.5	–	–	V/μs	
	Power = High	0.5	–	–	V/μs	
BW _{OBS}	Small Signal Bandwidth, 20mV _{pp} , 3dB BW, 100pF Load					
	Power = Low	0.7	–	–	MHz	
	Power = High	0.7	–	–	MHz	
BW _{OBS}	Large Signal Bandwidth, 1V _{pp} , 3dB BW, 100pF Load					
	Power = Low	200	–	–	kHz	
	Power = High	200	–	–	kHz	

3.4.9 AC Programming Specifications

The following table lists guaranteed maximum and minimum specifications for the voltage and temperature ranges: 4.75V to 5.25V and $-40^{\circ}\text{C} \leq T_A \leq 85^{\circ}\text{C}$, or 3.0V to 3.6V and $-40^{\circ}\text{C} \leq T_A \leq 85^{\circ}\text{C}$, respectively. Typical parameters apply to 5V and 3.3V at 25°C and are for design guidance only.

Table 3-27. AC Programming Specifications

Symbol	Description	Min	Typ	Max	Units	Notes
T_{RSCLK}	Rise Time of SCLK	1	–	20	ns	
T_{FSCLK}	Fall Time of SCLK	1	–	20	ns	
T_{SSCLK}	Data Set up Time to Falling Edge of SCLK	40	–	–	ns	
T_{HSCLK}	Data Hold Time from Falling Edge of SCLK	40	–	–	ns	
F_{SCLK}	Frequency of SCLK	0	–	8	MHz	
T_{ERASEB}	Flash Erase Time (Block)	–	10	–	ms	
T_{WRITE}	Flash Block Write Time	–	30	–	ms	
T_{DSCLK}	Data Out Delay from Falling Edge of SCLK	–	–	45	ns	$V_{dd} > 3.6$
T_{DSCLK3}	Data Out Delay from Falling Edge of SCLK	–	–	50	ns	$3.0 \leq V_{dd} \leq 3.6$

3.4.10 AC I²C Specifications

The following table lists guaranteed maximum and minimum specifications for the voltage and temperature ranges: 4.75V to 5.25V and $-40^{\circ}\text{C} \leq T_A \leq 85^{\circ}\text{C}$, or 3.0V to 3.6V and $-40^{\circ}\text{C} \leq T_A \leq 85^{\circ}\text{C}$, respectively. Typical parameters apply to 5V and 3.3V at 25°C and are for design guidance only.

Table 3-28. AC Characteristics of the I²C SDA and SCL Pins for V_{dd}

Symbol	Description	Standard Mode		Fast Mode		Units	Notes
		Min	Max	Min	Max		
F _{SCL I2C}	SCL Clock Frequency	0	100	0	400	kHz	
T _{HDSTA I2C}	Hold Time (repeated) START Condition. After this period, the first clock pulse is generated.	4.0	–	0.6	–	μs	
T _{LOW I2C}	LOW Period of the SCL Clock	4.7	–	1.3	–	μs	
T _{HIGH I2C}	HIGH Period of the SCL Clock	4.0	–	0.6	–	μs	
T _{SUSTA I2C}	Set-up Time for a Repeated START Condition	4.7	–	0.6	–	μs	
T _{HDDAT I2C}	Data Hold Time	0	–	0	–	μs	
T _{SUDAT I2C}	Data Set-up Time	250	–	100 ^a	–	ns	
T _{SUSTOI2C}	Set-up Time for STOP Condition	4.0	–	0.6	–	μs	
T _{BUFI2C}	Bus Free Time Between a STOP and START Condition	4.7	–	1.3	–	μs	
T _{SPI2C}	Pulse Width of spikes are suppressed by the input filter.	–	–	0	50	ns	

a. A Fast-Mode I2C-bus device can be used in a Standard-Mode I2C-bus system, but the requirement $t_{\text{SU:DAT}} \geq 250$ ns must then be met. This will automatically be the case if the device does not stretch the LOW period of the SCL signal. If such device does stretch the LOW period of the SCL signal, it must output the next data bit to the SDA line $t_{\text{rmax}} + t_{\text{SU:DAT}} = 1000 + 250 = 1250$ ns (according to the Standard-Mode I2C-bus specification) before the SCL line is released.

Figure 3-6. Definition for Timing for Fast/Standard Mode on the I²C Bus

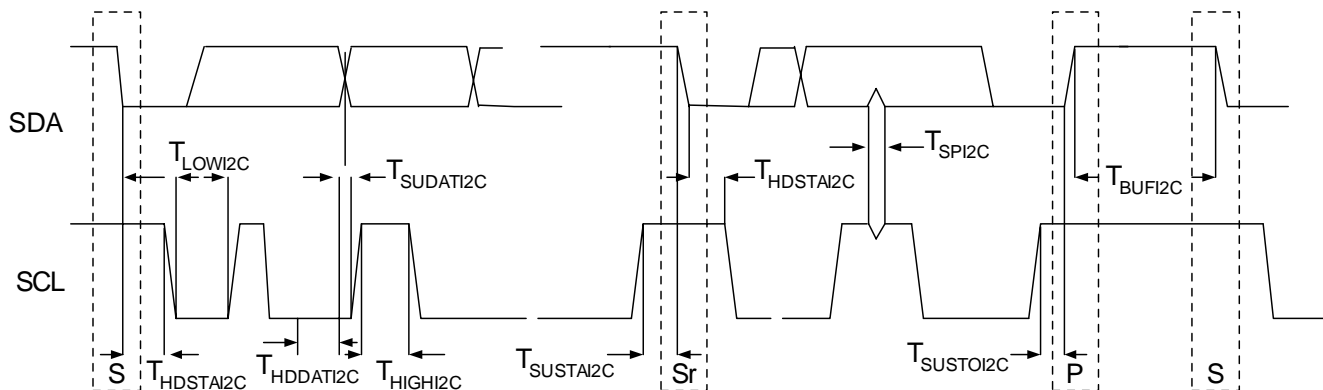

4. Packaging Information



This chapter illustrates the package specification for the CY8C24x94 PSoC devices, along with the thermal impedance for the package and solder reflow peak temperatures.

Important Note Emulation tools may require a larger area on the target PCB than the chip's footprint. For a detailed description of the emulation tools' dimensions, refer to the document titled *PSoC Emulator Pod Dimensions* at <http://www.cypress.com/design/MR10161>.

4.1 Packaging Dimensions

Figure 4-1. 56-Lead (8x8 mm) QFN

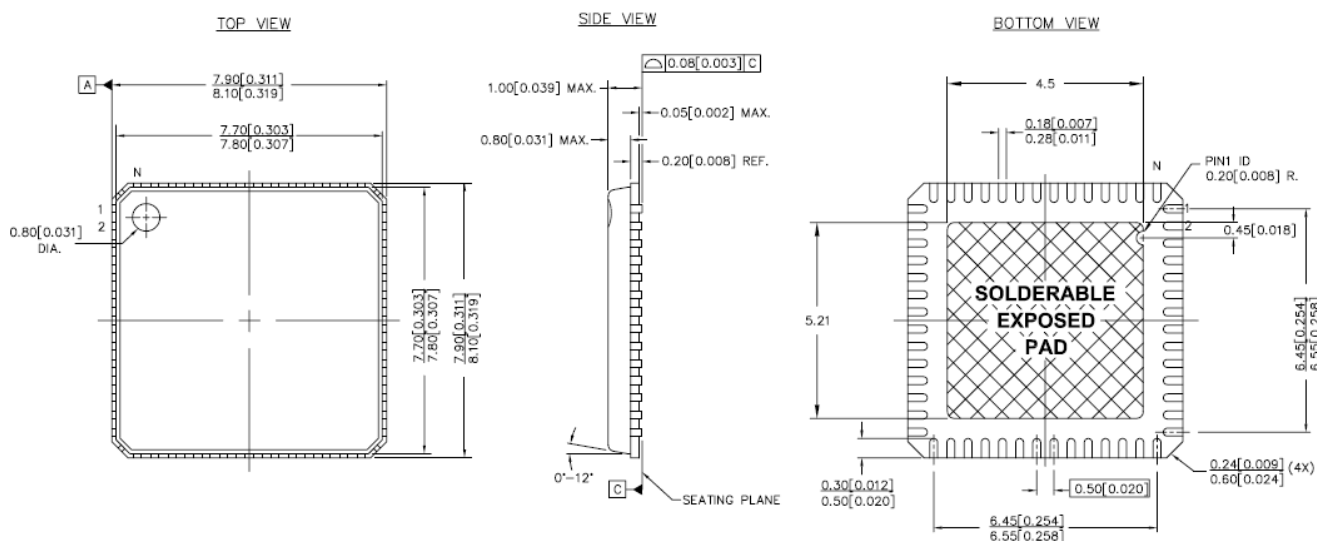

NOTES:

1. [HATCH] HATCH AREA IS SOLDERABLE EXPOSED METAL.
2. REFERENCE JEDEC#: MO-220
3. PACKAGE WEIGHT: 0.162g
4. ALL DIMENSIONS ARE IN MM [MIN/MAX]
5. PACKAGE CODE

PART #	DESCRIPTION
LF56A	STANDARD
LY56A	PB-FREE

001-12921 **

Figure 4-2. 68-Lead (8x8 mm x 0.89 mm) QFN

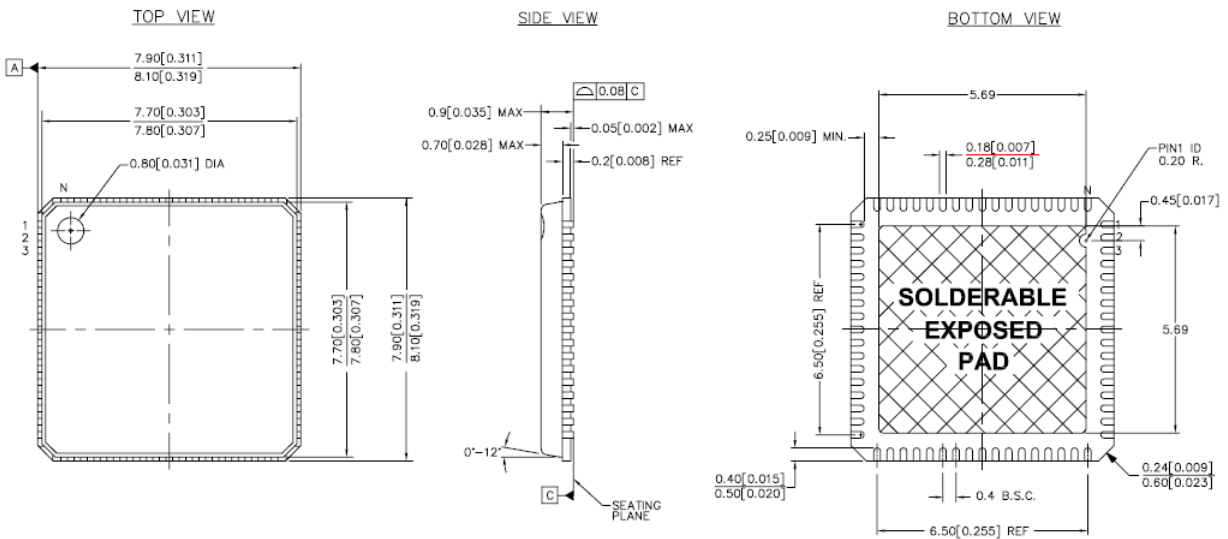

NOTES:

1. HATCH IS SOLDERABLE EXPOSED PAD.
2. REFERENCE JEDEC#: MO-220
3. PACKAGE WEIGHT: 0.17g
4. ALL DIMENSIONS ARE IN MM [MIN/MAX]
5. PACKAGE CODE

NOTE: EXPOSED PAD DIMENSION VARIES BY LEADFRAME CAVITY (PADDLE) SIZE

PART #	DESCRIPTION
LF68	STANDARD
LY68	PB-FREE

51-85214 °C

Important Note For information on the preferred dimensions for mounting QFN packages, see the following Application Note at http://www.amkor.com/products/notes_papers/MLFAppNote.pdf.

Important Note Pinned vias for thermal conduction are not required for the low-power PSoC device.

Figure 4-3. 100-Ball (6x6 mm) VFBGA

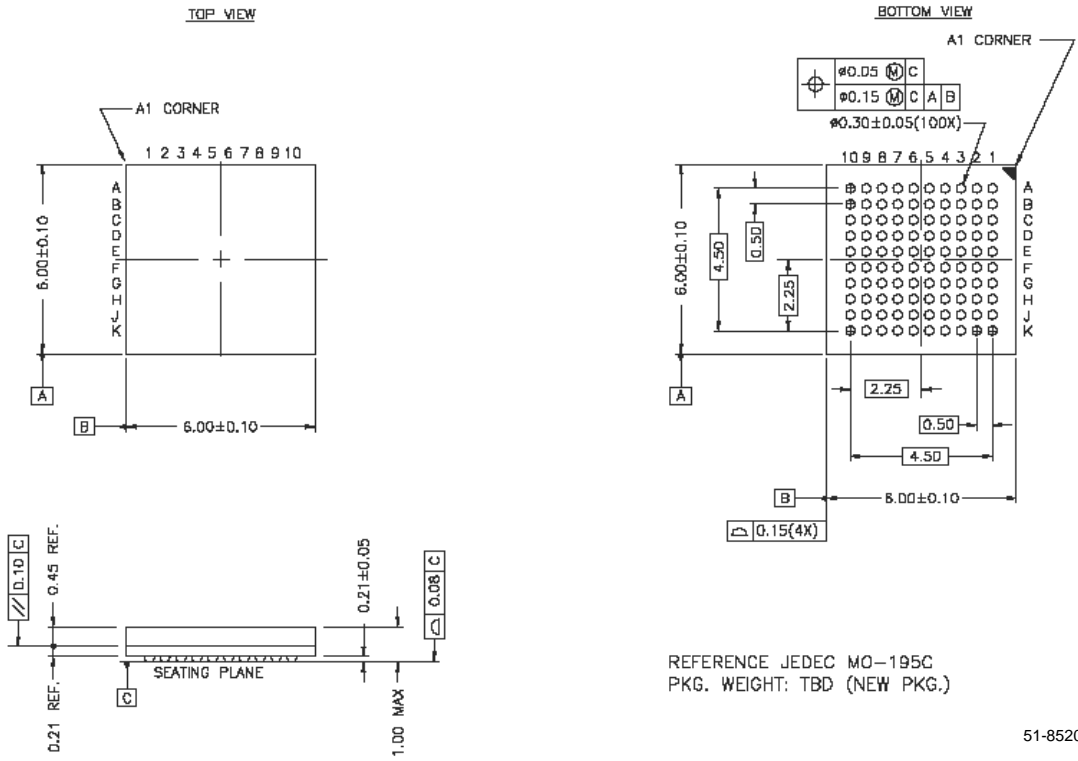
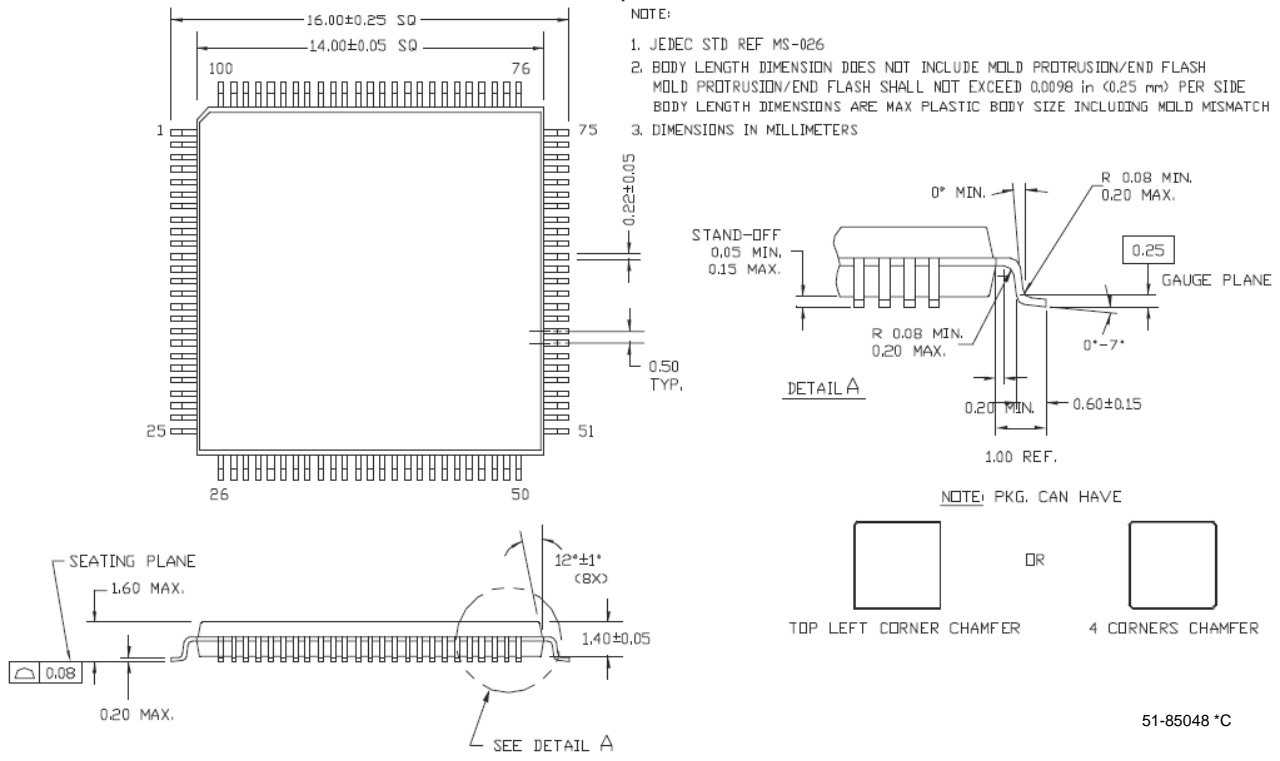

Figure 4-4. 100-Lead (14x14 x 1.4 mm) TQFP



4.2 Thermal Impedance

Table 4-1. Thermal Impedance for the Package

Package	Typical θ_{JA} *
56 QFN**	12.93 °C/W
68 QFN**	13.05 °C/W
100 VFBGA	65 °C/W

$$* T_J = T_A + \text{POWER} \times \theta_{JA}$$

** To achieve the thermal impedance specified for the QFN package, the center thermal pad should be soldered to the PCB ground plane.

4.3 Solder Reflow Peak Temperature

Following is the minimum solder reflow peak temperature to achieve good solderability.

Table 4-2. Solder Reflow Peak Temperature

Package	Minimum Peak Temperature*	Maximum Peak Temperature
56 QFN	240°C	260°C
68 QFN	240°C	260°C
100 VFBGA	240°C	260°C

*Higher temperatures may be required based on the solder melting point. Typical temperatures for solder are $220 \pm 5^\circ\text{C}$ with Sn-Pb or $245 \pm 5^\circ\text{C}$ with Sn-Ag-Cu paste. Refer to the solder manufacturer specifications.

5. Development Tool Selection



This chapter presents the development tools available for all current PSoC device families including the CY8C24x94 family.

5.1 Software

5.1.1 PSoC Designer™

At the core of the PSoC development software suite is PSoC Designer. Utilized by thousands of PSoC developers, this robust software has been facilitating PSoC designs for half a decade. PSoC Designer is available free of charge at <http://www.cypress.com> under DESIGN RESOURCES >> Software and Drivers.

5.1.2 PSoC Express™

As the newest addition to the PSoC development software suite, PSoC Express is the first visual embedded system design tool that allows a user to create an entire PSoC project and generate a schematic, BOM, and data sheet without writing a single line of code. Users work directly with application objects such as LEDs, switches, sensors, and fans. PSoC Express is available free of charge at <http://www.cypress.com/psocexpress>.

5.1.3 PSoC Programmer

Flexible enough to be used on the bench in development, yet suitable for factory programming, PSoC Programmer works either as a standalone programming application or it can operate directly from PSoC Designer or PSoC Express. PSoC Programmer software is compatible with both PSoC ICE-Cube In-Circuit Emulator and PSoC MiniProg. PSoC programmer is available free of charge at <http://www.cypress.com/psocprogrammer>.

5.1.4 CY3202-C iMAGEcraft C Compiler

CY3202 is the optional upgrade to PSoC Designer that enables the iMAGEcraft C compiler. It can be purchased from the Cypress Online Store. At <http://www.cypress.com>, click the Online Store shopping cart icon at the bottom of the web page, and click *PSoC (Programmable System-on-Chip)* to view a current list of available items..

5.2 Development Kits

All development kits can be purchased from the Cypress Online Store.

5.2.1 CY3215-DK Basic Development Kit

The CY3215-DK is for prototyping and development with PSoC Designer. This kit supports in-circuit emulation and the software interface allows users to run, halt, and single step the processor and view the content of specific memory locations. Advance emulation features also supported through PSoC Designer. The kit includes:

- PSoC Designer Software CD
- ICE-Cube In-Circuit Emulator
- ICE Flex-Pod for CY8C29x66 Family
- Cat-5 Adapter
- Mini-Eval Programming Board
- 110 ~ 240V Power Supply, Euro-Plug Adapter
- iMAGEcraft C Compiler (Registration Required)
- ISSP Cable
- USB 2.0 Cable and Blue Cat-5 Cable
- 2 CY8C29466-24PXI 28-PDIP Chip Samples

5.2.2 CY3210-ExpressDK PSoC Express Development Kit

The CY3210-ExpressDK is for advanced prototyping and development with PSoC Express (may be used with ICE-Cube In-Circuit Emulator). It provides access to I²C buses, voltage reference, switches, upgradeable modules and more. The kit includes:

- PSoC Express Software CD
- Express Development Board
- 4 Fan Modules
- 2 Proto Modules
- MiniProg In-System Serial Programmer
- MiniEval PCB Evaluation Board
- Jumper Wire Kit
- USB 2.0 Cable
- Serial Cable (DB9)
- 110 ~ 240V Power Supply, Euro-Plug Adapter
- 2 CY8C24423A-24PXI 28-PDIP Chip Samples
- 2 CY8C27443-24PXI 28-PDIP Chip Samples
- 2 CY8C29466-24PXI 28-PDIP Chip Samples

5.3 Evaluation Tools

All evaluation tools can be purchased from the Cypress Online Store.

5.3.1 CY3210-MiniProg1

The CY3210-MiniProg1 kit allows a user to program PSoC devices via the MiniProg1 programming unit. The MiniProg is a small, compact prototyping programmer that connects to the PC via a provided USB 2.0 cable. The kit includes:

- MiniProg Programming Unit
- MiniEval Socket Programming and Evaluation Board
- 28-Pin CY8C29466-24PXI PDIP PSoC Device Sample
- 28-Pin CY8C27443-24PXI PDIP PSoC Device Sample
- PSoC Designer Software CD
- Getting Started Guide
- USB 2.0 Cable

5.3.2 CY3210-PSoCEval1

The CY3210-PSoCEval1 kit features an evaluation board and the MiniProg1 programming unit. The evaluation board includes an LCD module, potentiometer, LEDs, and plenty of breadboarding space to meet all of your evaluation needs. The kit includes:

- Evaluation Board with LCD Module
- MiniProg Programming Unit
- 28-Pin CY8C29466-24PXI PDIP PSoC Device Sample (2)
- PSoC Designer Software CD
- Getting Started Guide
- USB 2.0 Cable

5.3.3 CY3214-PSoCEvalUSB

The CY3214-PSoCEvalUSB evaluation kit features a development board for the CY8C24794-24LFXI PSoC device. Special features of the board include both USB and capacitive sensing development and debugging support. This evaluation board also includes an LCD module, potentiometer, LEDs, an enunciator and plenty of bread boarding space to meet all of your evaluation needs. The kit includes:

- PSoCEvalUSB Board
- LCD Module
- MiniProg Programming Unit
- Mini USB Cable
- PSoC Designer and Example Projects CD
- Getting Started Guide
- Wire Pack

5.4 Device Programmers

All device programmers can be purchased from the Cypress Online Store.

5.4.1 CY3216 Modular Programmer

The CY3216 Modular Programmer kit features a modular programmer and the MiniProg1 programming unit. The modular programmer includes three programming module cards and supports multiple Cypress products. The kit includes:

- Modular Programmer Base
- 3 Programming Module Cards
- MiniProg Programming Unit
- PSoC Designer Software CD
- Getting Started Guide
- USB 2.0 Cable

5.4.2 CY3207ISSP In-System Serial Programmer (ISSP)

The CY3207ISSP is a production programmer. It includes protection circuitry and an industrial case that is more robust than the MiniProg in a production-programming environment.

Note: CY3207ISSP needs special software and is not compatible with PSoC Programmer. The kit includes:

- CY3207 Programmer Unit
- PSoC ISSP Software CD
- 110 ~ 240V Power Supply, Euro-Plug Adapter
- USB 2.0 Cable

5.5 Accessories (Emulation and Programming)

Table 5-1. Emulation and Programming Accessories

Part #	Pin Package	Flex-Pod Kit ^a	Foot Kit ^b	Adapter ^c
CY8C24794-24LFXI	56 QFN	CY3250-24X94QFN	CY3250-56QFN-FK	AS-56-28
CY8C24894-24LFXI	56 QFN	CY3250-24X94QFN	CY3250-56QFN-FK	AS-28-28-02SS-6ENG-GANG

- a. Flex-Pod kit includes a practice flex-pod and a practice PCB, in addition to two flex-pods.
- b. Foot kit includes surface mount feet that can be soldered to the target PCB.
- c. Programming adapter converts non-DIP package to DIP footprint. Specific details and ordering information for each of the adapters can be found at <http://www.emulation.com>.

5.6 3rd-Party Tools

Several tools have been specially designed by the following 3rd-party vendors to accompany PSoC devices during development and production. Specific details for each of these tools can be found at <http://www.cypress.com> under DESIGN RESOURCES >> Evaluation Boards.

5.7 Build a PSoC Emulator into Your Board

For details on how to emulate your circuit before going to volume production using an on-chip debug (OCD) non-production PSoC device, see Application Note "Debugging - Build a PSoC Emulator into Your Board - AN2323" at <http://www.cypress.com/an2323>.

6. Ordering Information



The following table lists the CY8C24x94 PSoC device's key package features and ordering codes.

Table 6-1. CY8C24x94 PSoC Device's Key Features and Ordering Information

Package	Ordering Code	Flash (Bytes)	SRAM (Bytes)	Temperature Range	Digital Blocks	Analog Blocks	Digital IO Pins	Analog Inputs	Analog Outputs	XRES Pin
56 Pin (8x8 mm) QFN	CY8C24794-24LFXI	16K	1K	-40C to +85C	4	6	50	48	2	No
56 Pin (8x8 mm) QFN (Tape and Reel)	CY8C24794-24LFXIT	16K	1K	-40C to +85C	4	6	50	48	2	No
56 Pin (8x8 mm) QFN	CY8C24894-24LFXI	16K	1K	-40C to +85C	4	6	49	47	2	Yes
56 Pin (8x8 mm) QFN (Tape and Reel)	CY8C24894-24LFXIT	16K	1K	-40C to +85C	4	6	49	47	2	Yes
68 Pin OCD (8x8 mm) QFN ^a	CY8C24094-24LFXI	16K	1K	-40C to +85C	4	6	56	48	2	Yes
68 Pin (8x8 mm) QFN	CY8C24994-24LFXI	16K	1K	-40C to +85C	4	6	56	48	2	Yes
68 Pin (8x8 mm) QFN (Tape and Reel)	CY8C24994-24LFXIT	16K	1K	-40C to +85C	4	6	56	48	2	Yes
100 Ball OCD (6x6 mm) VFBGA ^a	CY8C24094-24BVXI	16K	1K	-40C to +85C	4	6	56	48	2	Yes
100 Ball (6x6 mm) VFBGA	CY8C24994-24BVXI	16K	1K	-40C to +85C	4	6	56	48	2	Yes
100 Pin OCD TQFP ^a	CY8C24094-24AXI	16K	1K	-40C to +85C	4	6	56	48	2	Yes

a. This part may be used for in-circuit debugging. It is NOT available for production.

6.1 Ordering Code Definitions

CY 8 C 24 xxx-SPxx

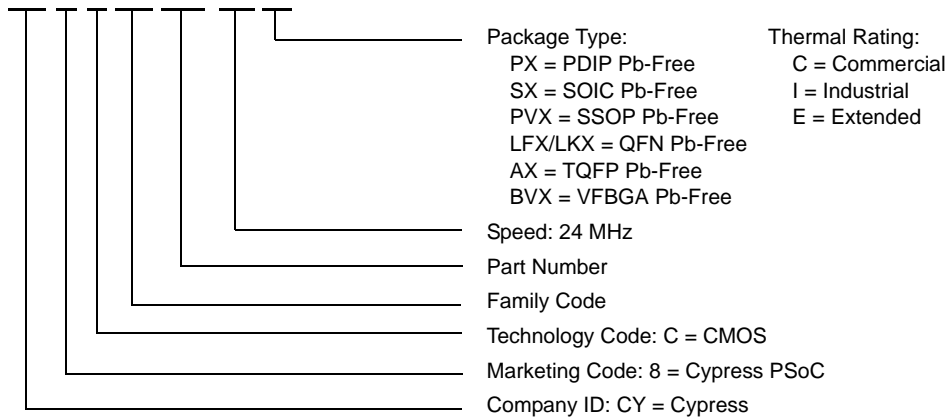

7. Sales and Company Information



To obtain information about Cypress Semiconductor or PSoC sales and technical support, reference the following information.

Cypress Semiconductor

198 Champion Court
San Jose, CA 95134
408.943.2600

Web Sites: Company Information – <http://www.cypress.com>
Sales – http://www.cypress.com/aboutus/sales_locations.cfm
Technical Support – <http://www.cypress.com/support/login.cfm>

7.1 Revision History

Table 6-1. CY8C24x94 Data Sheet Revision History

Document Title: CY8C24094, CY8C24794, CY8C24894 and CY8C24994 PSoC® Mixed-Signal Array Final Data Sheet				
Document Number: 38-12018				
Revision	ECN #	Issue Date	Origin of Change	Description of Change
**	133189	01.27.2004	NWJ	New silicon and new document – Advance Data Sheet.
*A	251672	See ECN	SFV	First Preliminary Data Sheet. Changed title to encompass only the CY8C24794 because the CY8C24494 and CY8C24694 are not being offered by Cypress MicroSystems.
*B	289742	See ECN	HMT	Add standard DS items from SFV memo. Add Analog Input Mux on pinouts. 2 MACs. Change 512 bytes of SRAM to 1K. Add dimension key to package. Remove HAPI. Update diagrams, registers and specs.
*C	335236	See ECN	HMT	Add CY logo. Update CY copyright. Update new CY.com URLs. Re-add ISSP programming pinout notation. Add Reflow Temp. table. Update features (MAC, Oscillator, and voltage range), registers (INT_CLR2/MSK2, second MAC), and specs. (Rext, IMO, analog output buffer...).
*D	344318	See ECN	HMT	Add new color and logo. Expand analog arch. diagram. Fix IO #. Update Electrical Specifications.
*E	346774	See ECN	HMT	Add USB temperature specifications. Make data sheet Final.
*F	349566	See ECN	HMT	Remove USB logo. Add URL to preferred dimensions for mounting MLF packages.
*G	393164	See ECN	HMT	Add new device, CY8C24894 56-pin MLF with XRES pin. Add Fimousb3v char. to specs. Upgrade to CY Perform logo and update corporate address and copyright.
*H	469243	See ECN	HMT	Add ISSP note to pinout tables. Update typical and recommended Storage Temperature per industrial specs. Update Low Output Level maximum IOL budget. Add FLS_PR1 to Register Map Bank 1 for users to specify which Flash bank should be used for SROM operations. Add two new devices for a 68-pin QFN and 100-ball VFBGA under RPNs: CY8C24094 and CY8C24994. Add two packages for 68-pin QFN. Add OCD non-production pinouts and package diagrams. Update CY branding and QFN convention. Add new Dev. Tool section. Update copyright and trademarks.
*I	561158	See ECN	HMT	Add Low Power Comparator (LPC) AC/DC electrical spec. tables. Add CY8C20x34 to PSoC Device Characteristics table. Add detailed dimensions to 56-pin QFN package diagram and update revision. Secure one package diagram/manufacturing per QFN. Update emulation pod/feet kit part numbers. Fix pinout type-o per TestTrack.
*J	728238	See ECN	HMT	Add CapSense SNR requirement reference. Update figure standards. Update Technical Training paragraphs. Add QFN package clarifications and dimensions. Update ECN-ed Amkor dimensioned QFN package diagram revisions. Reword SNR reference. Add new 56-pin QFN spec.
Distribution: External/Public			Posting: None	

7.2 Copyrights and Code Protection

© Cypress Semiconductor Corporation. 2004-2007. All rights reserved. PSoC Designer™, Programmable System-on-Chip™, and PSoC Express™ are trademarks and PSoC® is a registered trademark of Cypress Semiconductor Corp. All other trademarks or registered trademarks referenced herein are property of the respective corporations.

The information contained herein is subject to change without notice. Cypress Semiconductor assumes no responsibility for the use of any circuitry other than circuitry embodied in a Cypress Semiconductor product. Nor does it convey or imply any license under patent or other rights. Cypress Semiconductor does not authorize its products for use as critical components in life-support systems where a malfunction or failure may reasonably be expected to result in significant injury to the user. The inclusion of Cypress Semiconductor products in life-support systems application implies that the manufacturer assumes all risk of such use and in doing so indemnifies Cypress Semiconductor against all charges. Cypress Semiconductor products are not warranted nor intended to be used for medical, life-support, life-saving, critical control or safety applications, unless pursuant to an express written agreement with Cypress Semiconductor.

Note the following details of the Flash code protection features on Cypress Semiconductor PSoC devices.

Cypress Semiconductor products meet the specifications contained in their particular Cypress Semiconductor Data Sheets. Cypress Semiconductor believes that its family of products is one of the most secure families of its kind on the market today, regardless of how they are used. There may be methods, unknown to Cypress Semiconductor, that can breach the code protection features. Any of these methods, to our knowledge, would be dishonest and possibly illegal. Neither Cypress Semiconductor nor any other semiconductor manufacturer can guarantee the security of their code. Code protection does not mean that we are guaranteeing the product as "unbreakable." Cypress Semiconductor is willing to work with the customer who is concerned about the integrity of their code. Code protection is constantly evolving. We at Cypress Semiconductor are committed to continuously improving the code protection features of our products.